

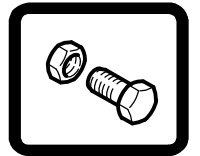

# S12



## Rider Sweeper Parts Manual



CE



For latest Parts manual or other  
language Operator manual, visit:

[www.tennantco.com/manuals](http://www.tennantco.com/manuals)

**331356**  
**Rev. 05 (2-2018)**



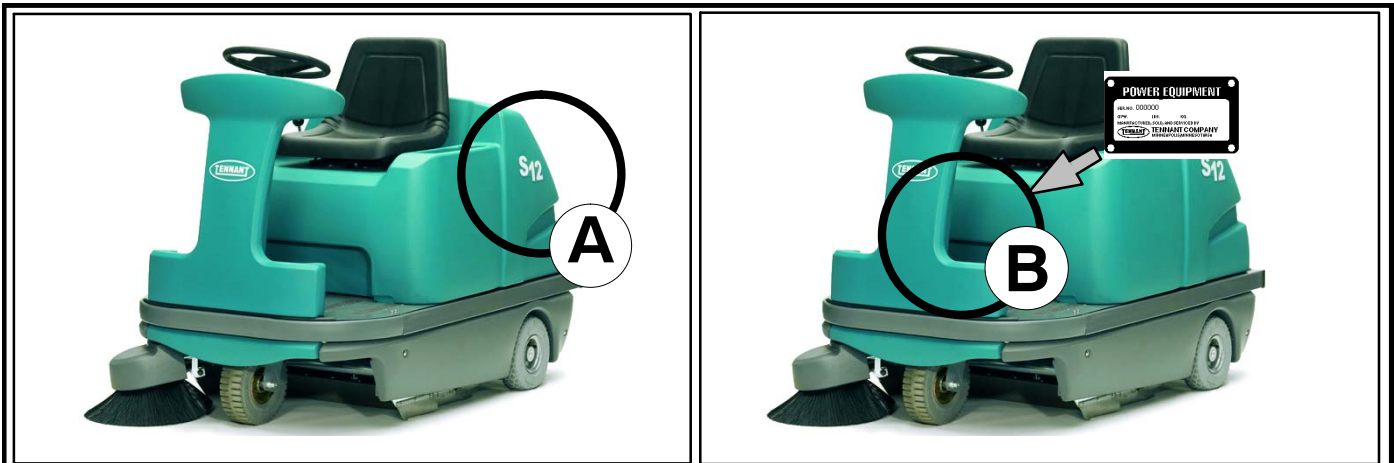

Ref	Part No.	Serial Number	Description	Qty.
1	82681	(000000— )	Bracket Wldt, Lpg Mount	1
2	63810	(000000— )	Latch Assy, Lpg Tank Mtg, W/Nut	4
3	51839	(000000— )	Nut Adjustable, Lpg Tank Mtg	2
4	49263	(000000— )	Tie, Cable	3
5	82556	(000000—001039)	Bracket, Vaporizer	1
6	54930	(000000— )	Vaporizer, LPG	1

**HOW TO ORDER PARTS – See diagram above**

Only use TENNANT Company supplied or equivalent parts. Parts and supplies may be ordered online, by phone, by fax or by mail.

Follow the steps below to ensure prompt delivery.

1. **(A)** Identify the machine model.
2. **(B)** Identify the machine serial number from the data plate.
3. **(C)** Ensure the proper serial number is used from the parts list.
4. Identify the part number and quantity. Do not order by page or reference numbers.
5. Provide your name, company name, customer ID number, billing and shipping address, phone number and purchase order number.
6. Provide detail shipping instructions.

**(D)** ▽ – identifies an assembly  
▲ – identifies parts included in assembly

**Please fill out at time of installation for future reference.**

Model No. – \_\_\_\_\_

Serial No. – \_\_\_\_\_

Machine Options – \_\_\_\_\_

Sales Rep. – \_\_\_\_\_

Sales Rep. phone no. – \_\_\_\_\_

Customer ID Number – \_\_\_\_\_

Installation Date – \_\_\_\_\_

**Tennant N.V.**  
 Industrielaan 6 5405 AB  
 P.O. Box 6 5400 AA Uden–The Netherlands  
 europe@tennantco.com  
 www.tennantco.com

<b>BG</b>	<p><b>КАК ДА ПОРЪЧВАМЕ ЧАСТИ - Вижте схемата по-горе</b></p> <p>Използвайте само части, доставени от TENNANT или техни еквиваленти. Частите и доставките могат да се поръчат онлайн, по телефон, факс или по пощата.</p> <p>Следвайте долупосочените стъпки, за да си осигурите бърза и точна доставка.</p> <ol style="list-style-type: none"> <li><b>(A)</b> Посочете модела на машината.</li> <li><b>(B)</b> Посочете серийния номер на машината от табелката с техническите данни.</li> <li><b>(C)</b> Уверете се, че сте използвали точния серийен номер от списъка с части.</li> <li>Посочва номера на частта и количеството. Не поръчвайте части според страницата или референтните номера.</li> <li>Посочете своето име, наименованието на фирмата, клиентския номер, адреса за получаване на сметката и доставката, тел.номер и номера на поръчката.</li> <li>Посочете подробни инструкции за доставката.</li> </ol> <hr/> <p><b>(D)</b>    ▽ – посочва начин на монтаж            ▲ – посочва частите, включени в монтажа</p>	<p><b>Моля, попълнете по време на монтажа за бъдеща справка.</b></p> <p>Модел Э – _____</p> <p>Серийен Э – _____</p> <p>Опции на машината – _____</p> <p>Търговски представител – _____</p> <p>Тел. Э на търг. представител – _____</p> <p>Клиентски Э – _____</p> <p>Дата на монтаж – _____</p>
-----------	--	--

<b>CN</b>	<p><b>如何订购部件 – 参见下表</b></p> <p>仅使用 TENNANT 公司提供的或同等部件。部件和供应可以在线订购，通过电话、传真或邮件订购。</p> <p>请遵循下面的步骤确保及时交付。</p> <ol style="list-style-type: none"> <li><b>(A)</b> 确定机器型号。</li> <li><b>(B)</b> 从数据标签确定机器序列号。</li> <li><b>(C)</b> 确保使用部件列表中的正确序列号。</li> <li>确定部件号和数量。 不要按页面或参考编号订购。</li> <li>提供您的姓名、公司名称、客户 ID 号、付帐和送货地址、电话号码和采购单编号。</li> <li>提供详细的送货说明。</li> </ol> <hr/> <p><b>(D)</b>    ▽ – 确定组件            ▲ – 确定组件中包含的组件</p>	<p><b>请在安装时填写供未来参考。</b></p> <p>型号 – _____</p> <p>序列号 – _____</p> <p>机器选项 – _____</p> <p>销售代表 – _____</p> <p>销售代表电话号码 – _____</p> <p>客户 ID 编号 – _____</p> <p>安装日期 – _____</p>
-----------	--	--

<b>CZ</b>	<p><b>OBJEDNÁVÁNÍ DÍLŮ - Viz schéma výše.</b></p> <p>Používejte pouze díly dodané společností TENNANT Company nebo jim odpovídající. Díly a materiál lze objednat online, telefonem, faxem nebo poštou.</p> <p>Aby bylo zajištěno rychlé dodání, postupujte podle kroků uvedených níže.</p> <ol style="list-style-type: none"> <li><b>(A)</b> Zjistěte model stroje.</li> <li><b>(B)</b> Zjistěte sériové číslo stroje z výrobního štítku.</li> <li><b>(C)</b> Použijte správné sériové číslo ze seznamu dílů.</li> <li>Určete číslo a množství dílů. Neobjednávejte podle stran nebo referenčních čísel.</li> <li>Uveďte jméno, název společnosti, číslo ID zákazníka, fakturační a dodací adresu, telefonní číslo a číslo objednávky.</li> <li>Uveďte podrobné pokyny pro dodání.</li> </ol> <hr/> <p><b>(D)</b>    ▽ – označuje sestavu            ▲ – označuje díly v sestavě</p>	<p><b>Vypíšte během sestavování pro budoucí potřebu.</b></p> <p>Číslo modelu – _____</p> <p>Sériové číslo – _____</p> <p>Doplňky zařízení – _____</p> <p>Obchodní zástupce – _____</p> <p>Tel. č. obchodního zástupce – _____</p> <p>Číslo ID zákazníka – _____</p> <p>Datum instalace – _____</p>
-----------	---	--

<b>DE</b>	<p><b>BESTELLEN VON ERSATZTEILEN – Siehe oben stehendes Diagramm.</b></p> <p>Verwenden Sie nur von TENNANT gelieferte oder gleichwertige Ersatzteile. Ersatz- und Verschleißteile können online, telefonisch, per Fax oder per E-Mail bestellt werden.</p> <p>Befolgen Sie für eine umgehende Lieferung die folgenden Schritte.</p> <ol style="list-style-type: none"> <li><b>(A)</b> Geben Sie das Modell der Maschine an.</li> <li><b>(B)</b> Geben Sie die Seriennummer der Maschine an (auf dem Datenaufkleber).</li> <li><b>(C)</b> Achten Sie darauf, dass die richtigen Seriennummer aus der Ersatzteilliste verwendet wird.</li> <li>Geben Sie die Ersatzteilnummer und die Menge an. Bestellen Sie nicht nach Seitenzahl oder Referenznummern.</li> <li>Geben Sie Ihren Namen, den Firmennamen, die Kundennummer, die Rechnungs- und Lieferadresse, die Telefonnummer und die Einkaufsauftragsnummer an.</li> <li>Erteilen Sie genaue Versandanweisungen.</li> </ol> <hr/> <p><b>(D)</b>    ▽ – steht für eine Einheit            ▲ – steht für Einzelteile einer Einheit</p>	<p><b>Bitte bei der Inbetriebnahme als Referenzangabe ausfüllen.</b></p> <p>Modellnr. – _____</p> <p>Seriennr. – _____</p> <p>Maschinenoptionen – _____</p> <p>Verkäufer – _____</p> <p>Telefonnummer des Verkäufers – _____</p> <p>Kundennummer – _____</p> <p>Installationsdatum – _____</p>
-----------	--	--

<b>DK</b>	<p><b>BESTILLING AF RESERVEDELE – Se ovenstående tabel.</b></p> <p>Brug kun reservedele, der er fremstillet af TENNANT, eller dele af tilsvarende kvalitet. Reservedele og tilbehør kan bestilles online, pr. telefon, pr. fax eller pr. brev.</p> <p>Følg nedenstående trin for at sikre hurtig levering.</p> <ol style="list-style-type: none"> <li><b>(A)</b> Identificér maskinmodellen.</li> <li><b>(B)</b> Identificér maskinens serienummer på datamærkatet.</li> <li><b>(C)</b> Kontrollér, at det rigtige serienummer bruges i reservedelslisten.</li> <li>Identificér reservedelsnummeret og antallet. Bestil ikke efter side- eller referencenumre.</li> <li>Angiv dit navn, firmanavn, kunde-id-nummer, faktureringsadresse og leveringsadresse, telefonnummer og indkøbsordrenummer.</li> <li>Angiv detaljerede instruktioner til forsendelse.</li> </ol> <hr/> <p><b>(D)</b> ▽ – identificerer en enhed ▲ – identificerer reservedele i en enhed</p>	<p><b>Udfyld venligst på installationstidspunktet til fremtidig brug.</b></p> <p>Modelnr. – _____</p> <p>Serienr. – _____</p> <p>Maskineks-traudstyr – _____</p> <p>Salgskonsulent. – _____</p> <p>Salgskonsulentens tlf. – _____</p> <p>Kunde-id-nr. – _____</p> <p>Installationsdato – _____</p>
-----------	--	--

<b>EE</b>	<p><b>KUIDAS VARUOSI TELLIDA – vaadake alltoodud joonist</b></p> <p>Kasutage ainult TENNANT Company poolt tarnitud või samaväärseid varuosi. Varuosi ja tarvikuid saab tellida Interneti, telefoni, faksi või posti teel.</p> <p>Kiire kohaletoimetamise tagamiseks järgige alltoodud juhiseid.</p> <ol style="list-style-type: none"> <li><b>(A)</b> Märkige masina mudel.</li> <li><b>(B)</b> Märkige andmesildil olev masina seerianumber.</li> <li><b>(C)</b> Veenduge, et olete valinud varuosade loendist õige seerianumbri.</li> <li>Märkige varuosa number ja kogus. Ärge tellige lehekülje- või viitenumbri alusel.</li> <li>Märkige oma nimi, ettevõtte nimi, kliendinumbr ja arveldus- ja saatmisadress, telefoninumber ja ostutellimuse number.</li> <li>Lisage täpsed saatmisjuhised.</li> </ol> <hr/> <p><b>(D)</b> ▽ – tähistab komplekti ▲ – tähistab komplektis olevaid osi</p>	<p><b>Palun täitke paigaldamise ajal edaspidiseks viitamiseks.</b></p> <p>Mudelil number – _____</p> <p>Seerianumber – _____</p> <p>Masina lisavarustus – _____</p> <p>Müügiesindus – _____</p> <p>Müügiesinduse telefoninumber – _____</p> <p>Kliendinumber – _____</p> <p>Paigaldamise kuupäev – _____</p>
-----------	--	--

<b>ES</b>	<p><b>CÓMO SOLICITAR PIEZAS – Consulte el diagrama anterior.</b></p> <p>Utilice sólo las piezas suministradas por TENNANT Company o piezas equivalentes. Puede solicitar las piezas a través de internet, por teléfono, por fax o por correo.</p> <p>Siga los siguientes pasos para que la entrega sea rápida.</p> <ol style="list-style-type: none"> <li><b>(A)</b> Indique el modelo de máquina.</li> <li><b>(B)</b> Indique el número de serie de la etiqueta de datos.</li> <li><b>(C)</b> Asegúrese de que indica el número de serie correcto de la lista de piezas.</li> <li>Indique la cantidad y el número de la pieza. No realice el pedido indicando el número de página o el de referencia.</li> <li>Incluya su nombre, el nombre de la empresa, el ID de cliente, las direcciones de envío y facturación, el número de teléfono y el número del pedido de compra.</li> <li>Facilite instrucciones de envío.</li> </ol> <hr/> <p><b>(D)</b> ▽ – identifica un conjunto ▲ – identifica piezas de un conjunto</p>	<p><b>Rellene estos datos cuando realice la instalación para utilizarlos como referencia en el futuro.</b></p> <p>Nº modelo – _____</p> <p>Nº serie – _____</p> <p>Opciones de la máquina – _____</p> <p>Vendedor – _____</p> <p>Nº teléfono vendedor – _____</p> <p>Nº cliente – _____</p> <p>Fecha de instalación – _____</p>
-----------	--	---

<b>FI</b>	<p><b>KUINKA VARAOSIA TILATAAN – katso kuvaa yllä.</b></p> <p>Käytä ainoastaan TENNANTIN toimittamia tai niitä vastaavia varaosia. Voit tilata varaosia ja tarvikkeita internetistä, puhelimitse, faksilla tai sähköpostilla.</p> <p>Noudata seuraavia ohjeita täsmällisen toimituksen varmistamiseksi.</p> <ol style="list-style-type: none"> <li><b>(A)</b> Katso koneen malli.</li> <li><b>(B)</b> Katso koneen sarjanumero sen tunnustarrasta.</li> <li><b>(C)</b> Varmista, että osaluettelosta, että käytät oikeaa sarjanumeroa.</li> <li>Katso osanumero ja kappalemäärä. Älä tilaa ilmoittamalla sivu- tai viitenumeroita.</li> <li>Ilmoita nimesi, yrityksesi nimi, asiakasnumero, laskutus- ja toimitusosoite, puhelinnumero ja ostotilauksen numero.</li> <li>Ilmoita yksityiskohtaiset toimitusosoitteet.</li> </ol> <hr/> <p><b>(D)</b> ▽ – tarkoittaa kokoonpanoa ▲ – tarkoittaa kokoonpanoon sisältyviä osia</p>	<p><b>Ole hyvä ja täytä ottaessasi koneen käyttöön myöhempiä tarpeita varten.</b></p> <p>Mallinnumero – _____</p> <p>Sarjanumero – _____</p> <p>Koneen lisävarusteet – _____</p> <p>Myyntiedustaja – _____</p> <p>Myyntiedustajan puhelinnumero – _____</p> <p>Asiakasnumero – _____</p> <p>Asennuspäivä – _____</p>
-----------	---	--

<b>FR</b>	<p><b>COMMENT COMMANDER DES PIÈCES DÉTACHÉES – Voir le schéma ci-dessus.</b></p> <p>Utilisez uniquement des pièces fournies par la société TENNANT ou équivalentes. Les pièces et fournitures peuvent être commandées en ligne, par téléphone, fax, ou par courrier.</p> <p>Suivez les étapes ci-dessous pour assurer une livraison rapide.</p> <ol style="list-style-type: none"> <li><b>(A)</b> Identifiez le modèle de la machine.</li> <li><b>(B)</b> Identifiez le numéro de série de la machine, à partir de l'étiquette signalétique.</li> <li><b>(C)</b> Assurez-vous que le numéro de série correct est utilisé à partir de la liste de pièces détachées.</li> <li>Identifiez le numéro de pièce et la quantité. Ne commandez pas par page ou numéros de référence.</li> <li>Fournissez votre nom, le nom de votre société, votre numéro d'identification de client, l'adresse de facturation et d'expédition, le numéro de téléphone et le numéro du bon de commande.</li> <li>Fournissez des instructions d'expédition détaillées.</li> </ol> <hr/> <p><b>(D)</b> ▽ – identifie un assemblage ▲ – identifie les pièces composant l'assemblage</p>	<p><b>A remplir au moment de l'installation à titre de référence.</b></p> <p>N° du modèle – _____</p> <p>N° de série – _____</p> <p>Options de la machine – _____</p> <p>Agent commercial – _____</p> <p>N° tél. de l'agent commercial – _____</p> <p>Numéro d'identification client – _____</p> <p>Date d'installation – _____</p>
-----------	--	---

<b>GR</b>	<p><b>ΤΡΟΠΟΣ ΠΑΡΑΓΓΕΛΙΑΣ ΑΝΤΑΛΛΑΚΤΙΚΩΝ - Βλ. παραπάνω διάγραμμα.</b></p> <p>Χρησιμοποιήστε μόνο ανταλλακτικά παρεχόμενα από την TENNANT Company ή ισοδύναμα. Τα ανταλλακτικά και αναλώσιμα μπορούν να παραγγελθούν online, τηλεφωνικά, με φαξ ή ταχυδρομικά.</p> <p>Ακολουθήστε τα παρακάτω βήματα για να εξασφαλίσετε την έγκαιρη αποστολή τους.</p> <ol style="list-style-type: none"> <li><b>(A)</b> Βρείτε το μοντέλο μηχανήματος.</li> <li><b>(B)</b> Βρείτε τον αριθμό σειράς του μηχανήματος από την ετικέτα στοιχείων.</li> <li><b>(C)</b> Βεβαιωθείτε ότι χρησιμοποιείται ο σωστός αριθμός σειράς από τον κατάλογο ανταλλακτικών.</li> <li>Βρείτε κωδικό ανταλλακτικού και ποσότητα. Μην παραγγέλνετε βάσει σελίδας ή αριθμών αναφοράς.</li> <li>Δώστε το όνομα σας, όνομα εταιρείας, ID (κωδικό) πελάτη, διεύθυνση τιμολόγησης και αποστολής, αριθμό τηλεφώνου και αριθμό εντολής προμήθειας.</li> <li>Δώστε λεπτομερείς πληροφορίες αποστολής.</li> </ol> <hr/> <p><b>(D)</b> ▽ – υποδηλώνει υποσύστημα ▲ – υποδηλώνει τα μέρη που περιλαμβάνονται στο υποσύστημα</p>	<p><b>Παρακαλούμε συμπληρώστε κατά την ώρα της εγκατάστασης για μελλοντική αναφορά.</b></p> <p>Αρ. Μοντέλου – _____</p> <p>Αρ. σειράς – _____</p> <p>Επιλογές Μηχανήματος – _____</p> <p>Εκπ. πωλήσεων – _____</p> <p>Τηλ. εκπροσώπου πωλήσεων – _____</p> <p>Αριθμός πελάτη – _____</p> <p>Ημερομηνία εγκατάστασης – _____</p>
-----------	--	---

<b>HU</b>	<p><b>HOGYAN RENDELJÜNK ALKATRÉSZEKET - Lásd: fenti diagramm.</b></p> <p>Kizárólag TENNANT vagy azzal egyenértékű cserealkatrészeket használjon. Az alkatrészeket és anyagokat meg lehet rendelni az Interneten keresztül, vagy telefonon, faxon és e-mailben.</p> <p>A pontos szállítás érdekében kövesse az alábbi lépéseket.</p> <ol style="list-style-type: none"> <li><b>(A)</b> Adja meg a gép típusát.</li> <li><b>(B)</b> Az adatcímke alapján adja meg a gép gyártási számát.</li> <li><b>(C)</b> Ügyeljen arra, hogy a megfelelő gyártási számot válassza ki az alkatrészlistáról.</li> <li>Adja meg a rendelési számot és a mennyiséget. A rendeléshez ne az oldalszámot vagy a hivatkozási számot használja.</li> <li>Adja meg a nevét, a cége nevét, az ügyfélaazonosító számát, a számlázási és szállítási címét, a telefonszámát és a rendelési számot.</li> <li>Adjon részletes szállítási utasításokat.</li> </ol> <hr/> <p><b>(D)</b> ▽ – a jel csomagra utal ▲ – a jel a csomagban található alkatrészekre utal</p>	<p><b>A későbbi visszakeresések érdekében kérjük, hogy a rovatokat az első üzembehelyezéskor töltsse ki.</b></p> <p>Típuszám – _____</p> <p>Gyártási szám. – _____</p> <p>A gép felszereltsége – _____</p> <p>Kereskedelmi képviselő – _____</p> <p>Kereskedelmi képviselő telefonszáma – _____</p> <p>Ügyfél azonosító száma – _____</p> <p>Üzembehelyezés dátuma – _____</p>
-----------	--	--

<b>IT</b>	<p><b>COME ORDINARE LE PARTI – Vedere schema precedente.</b></p> <p>Utilizzare solo ricambi forniti da TENNANT o equivalenti. Ricambi e forniture possono essere ordinati online, per telefono, via fax o per posta elettronica.</p> <p>Per ottenere una consegna rapida, seguire i passaggi indicati di seguito.</p> <ol style="list-style-type: none"> <li><b>(A)</b> Identificare il modello della macchina.</li> <li><b>(B)</b> Identificare il numero di serie della macchina dall'etichetta dei dati.</li> <li><b>(C)</b> Utilizzare il numero di serie corretto presente nell'elenco delle parti di ricambio.</li> <li>Identificare numero di parte e quantità. Non ordinare per numero di pagina o di riferimento.</li> <li>Fornire nome del contatto, nome della società, numero di ID cliente, indirizzo di fatturazione e di spedizione, numero di telefono e numero di ordine di acquisto.</li> <li>Fornire istruzioni dettagliate per la spedizione.</li> </ol> <hr/> <p><b>(D)</b> ▽ – identifica un gruppo ▲ – identifica parti comprese in un gruppo</p>	<p><b>Compilare il modulo al momento dell'installazione per poterlo consultare in futuro in caso di necessità.</b></p> <p>N. Modello – _____</p> <p>N. Serie – _____</p> <p>Opzioni della macchina – _____</p> <p>Venditore – _____</p> <p>Tel. venditore – _____</p> <p>Numero ID cliente – _____</p> <p>Data di installazione – _____</p>
-----------	--	---

<b>JP</b>	<p><b>パーツの発注方法 ? 上記の図を参照してください</b></p> <p>TENNANT社製のパーツまたは同等品のみをお使いください。          パーツやサプライ品のご注文は、オンライン、電話、FAX、または手紙でお願いいたします。          確実にお届けできるように、以下の情報お知らせください。</p> <ol style="list-style-type: none"> <li><b>(A)</b> 製品のモデル名をお知らせください。</li> <li><b>(B)</b> 製品のデータラベルに印刷されているシリアル番号をお知らせください。</li> <li><b>(C)</b> パーツリストを参照して、シリアル番号が正しいかご確認ください。</li> <li>パーツ番号と数量をお知らせください。マニュアル/カタログのページ番号や参照番号でのご注文はご遠慮ください。</li> <li>お客様のお名前、会社名、顧客ID番号、請求/発送先住所、電話番号、注文書番号をお知らせください。</li> <li>発送に関するご希望があれば、明記してください。</li> </ol> <hr/> <p><b>(D)</b> ▽ - アセンブリを示します          ▲ - アセンブリに含まれるパーツを示します</p>	<p><b>後日確認できるように、設置時に記入してください。</b></p> <p>モデルNo. - _____</p> <p>シリアルNo. - _____</p> <p>製品のオプション - _____</p> <p>販売代理店 - _____</p> <p>販売代理店の電話番号 - _____</p> <p>顧客ID番号 - _____</p> <p>設置日 - _____</p>
-----------	--	---

<b>LT</b>	<p><b>KAIP UŽSISAKYTI DALIS – žr. diagramą viršuje</b></p> <p>Naudokite tik "Tennant" kompanijos tiekiamas arba lygiavertes joms dalis. Dalis galite užsisakyti internetu, telefonu, faksu bei elektroniniu paštu.          Kad užsakymas būtų greitai įvykdytas, laikykitės išvardytų taisyklių.</p> <ol style="list-style-type: none"> <li><b>(A)</b> Nurodykite mašinos modelį.</li> <li><b>(B)</b> Norodyskite mašinos serijos numerį, kurį rasite ant duomenų žymės.</li> <li><b>(C)</b> Įsitinkinkite, kad nurodomas tikslus serijos numeris iš dalių sąrašo.</li> <li>Nurodykite dalies numerį ir reikiamą kiekį.          Neužsakinėkite pagal puslapius ar nuorodas numerius.</li> <li>Nurodykite savo vardą, kompanijos pavadinimą, kliento ID numerį, sąskaitos išrašymo ir vežimo adresą, telefono numerį ir pirkimo užsakymo numerį.</li> <li>Nurodykite išsamias gabenimo instrukcijas.</li> </ol> <hr/> <p><b>(D)</b> ▽ – žymi sistemą          ▲ – nurodo sistemos dalis</p>	<p><b>Prašome užpildyti montavimo metu, siekiant gauti informaciją ateityje.</b></p> <p>Modelio nr. - _____</p> <p>Serijos nr. - _____</p> <p>Mašinos parinktys - _____</p> <p>Prekybos atstovas - _____</p> <p>Komivojažieriaus tel. nr. - _____</p> <p>Pirkėjo ID numeris - _____</p> <p>Sumontavimo data - _____</p>
-----------	--	---

<b>LV</b>	<p><b>KĀ PASŪTĪT REZERVES DETALĀS – Skat. diagrammu iepriekš</b></p> <p>izmantojiet tikai TENNANT Company piegādātās vai tām līdzvērtīgas rezerves detaļas. Daļas un piegādi var pasūtīt internetā, pa tālruni, pa faksu vai pastu.          Lai nodrošinātu savlaicīgu piegādi, sekojiet zemāk aprakstītajiem soļiem.</p> <ol style="list-style-type: none"> <li><b>(A)</b> Nosakiet mašinas modeli.</li> <li><b>(B)</b> Nosakiet mašinas sērijas numuru un tehnisko datu uzlīmes.</li> <li><b>(C)</b> Pārliedzieties, ka tiek uzrakstīts attiecīgais sērijas numurs no detaļu saraksta.</li> <li>Nosakiet detaļas numuru un skaitu.          Veicot pasūtījumus neatsaucieties uz lapušu vai norādes numuriem.</li> <li>Uzrakstiet savu vārdu, uzņēmuma nosaukumi, klienta identitātes numuru, adresi rēķina piesūtīšanai un piegādei un pirkuma pasūtījuma numuru.</li> <li>Sniedziet detalizētu informāciju par piegādi.</li> </ol> <hr/> <p><b>(D)</b> ▽ – nosaka ierīci          ▲ – nosaka detaļas, kas ir komplektā ar ierīci</p>	<p><b>Veicot uzstādīšanu, lūdzam pierakstīt attiecīgu informāciju izmantošanai turpmāk.</b></p> <p>Modeļa Nr. - _____</p> <p>Sērijas Nr. - _____</p> <p>Iekārtas papildaprīkojums - _____</p> <p>Pārdošanas pārst. - _____</p> <p>Pārdošanas pārst. tālr. Nr. - _____</p> <p>Klienta identitātes numuru - _____</p> <p>Uzstādīšanas datums - _____</p>
-----------	---	--

<b>NL</b>	<p><b>HOE ONDERDELEN TE BESTELLEN – Zie schema hierboven.</b></p> <p>Gebruik alleen onderdelen die door TENNANT Company zijn geleverd of soortgelijke onderdelen. Onderdelen en voorraden kunnen online, per telefoon, fax of schriftelijk besteld worden.          Volg de stappen hieronder om een juiste levering te garanderen.</p> <ol style="list-style-type: none"> <li><b>(A)</b> Bepaal het machinemodel.</li> <li><b>(B)</b> Lees het serienummer van de machine af van het gegevenslabel.</li> <li><b>(C)</b> Zorg dat het juiste serienummer wordt gebruikt uit de onderdelenlijst.</li> <li>Bepaal het artikelnummer en het aantal. Bestel niet aan de hand van pagina's of referentienummers</li> <li>Geef uw naam, bedrijfsnaam, klantnummer, factuur- en leveringsadres, telefoonnummer en bestelnummer op.</li> <li>Geef gedetailleerde leveringsinstructies op.</li> </ol> <hr/> <p><b>(D)</b> ▽ – geeft een eenheid aan          ▲ – geeft de onderdelen van de eenheid aan</p>	<p><b>Vul tijdens installatie de onderstaande gegevens in voor eventueel toekomstig gebruik.</b></p> <p>Modelnr. - _____</p> <p>Serienr. - _____</p> <p>Machine-opties - _____</p> <p>Verkoopvert. - _____</p> <p>Telnr. verkoopvert. - _____</p> <p>Klantnummer - _____</p> <p>Installatiedatum - _____</p>
-----------	--	--

<b>NO</b>	<p><b>HVORDAN BESTILLE DELER – Se diagram over.</b></p> <p>Bruk kun deler levert av TENNANT Company eller ekvivalente deler. Deler og forsyninger kan bestilles online, per telefon, per faks eller per post.</p> <p>Følg trinnene under for å sikre rask levering.</p> <ol style="list-style-type: none"> <li>1. <b>(A)</b> Angi maskinmodellen.</li> <li>2. <b>(B)</b> Angi maskinens serienummer fra typeskiltet.</li> <li>3. <b>(C)</b> Forsikre deg om at korrekt serienummer brukes fra delelisten.</li> <li>4. Angi delenummer og antall. Bestill ikke ut fra side- eller referansenumre.</li> <li>5. Angi ditt navn, firmanavn, kunde-ID-nummer, fakturerings- og forsendelsesadresse, telefonnummer og innkjøpsordnummer.</li> <li>6. Angi detaljerte forsendelsesinstruksjoner.</li> </ol> <hr/> <p><b>(D)</b>    ▽ – angir en delegruppe                 ▲ – angir deler inkludert i en delegruppe</p>	<p><b>Fyll ut ved installasjonstidspunkt for fremtidig bruk.</b></p> <p>Modellnr. – _____</p> <p>Serienr. – _____</p> <p>Maskinens tillegg – _____</p> <p>Salgsrep. – _____</p> <p>Salgsrep. telefonnr. – _____</p> <p>Kunde-ID-nummer – _____</p> <p>Installasjonsdato – _____</p>
-----------	---	---

<b>PL</b>	<p><b>JAK ZAMAWIAĆ CZĘŚCI - patrz schemat powyżej.</b></p> <p>Należy używać wyłącznie części dostarczanych przez firmę TENNANT Company lub równoważnych. Części i dostawy mogą być zamawiane online, przez telefon, faksem lub pocztą.</p> <p>Aby zapewnić szybką dostawę, należy przestrzegać następujących wskazówek.</p> <ol style="list-style-type: none"> <li>1. <b>(A)</b> Określić model maszyny.</li> <li>2. <b>(B)</b> Określić numer seryjny maszyny znajdujący się na tabliczce znamionowej.</li> <li>3. <b>(C)</b> Odszukać ten numer seryjny w wykazie części.</li> <li>4. Określić numer części i ilość. Nie zamawiać na podstawie numeru strony lub liczby porządkowej wykazu.</li> <li>5. Podać swoje nazwisko, nazwę firmy, numer identyfikacyjny klienta, adres dostawy i dostarczenia rachunku, numer telefonu i numer zamówienia zakupu.</li> <li>6. Podać dokładne instrukcje dotyczące dostawy.</li> </ol> <hr/> <p><b>(D)</b>    ▽ – oznacza zespół                 ▲ – oznacza część w zespole</p>	<p><b>Prosimy wpisać datę instalacji do późniejszego wykorzystania.</b></p> <p>Nr modelu – _____</p> <p>Nr seryjny – _____</p> <p>Opcje maszyny – _____</p> <p>Przedst. sprzedaży – _____</p> <p>Nr tel. przedst. sprzed. – _____</p> <p>Nr ident. klienta – _____</p> <p>Data instalacji – _____</p>
-----------	--	---

<b>PT G</b>	<p><b>COMO ENCOMENDAR PEÇAS – Consulte o diagrama acima.</b></p> <p>Utilize apenas peças fornecidas pela TENNANT Company ou equivalentes. As peças e consumíveis podem ser encomendados online, por telefone, fax ou correio.</p> <p>Siga os passos abaixo para garantir uma entrega rápida.</p> <ol style="list-style-type: none"> <li>1. <b>(A)</b> Identifique o modelo da máquina.</li> <li>2. <b>(B)</b> Identifique o número de série da máquina que se encontra na etiqueta de dados.</li> <li>3. <b>(C)</b> Certifique-se de que usa o número de série correcto da lista de peças.</li> <li>4. Identifique o número de produto e a quantidade. Não encomende através de números de página ou de referência.</li> <li>5. Forneça o seu nome, o nome da empresa, o número de ID do cliente, os endereços de facturação e entrega, o número de telefone e o número da nota de encomenda.</li> <li>6. Forneça instruções de entrega detalhadas.</li> </ol> <hr/> <p><b>(D)</b>    ▽ – identifica uma unidade                 ▲ – identifica peças incluídas numa unidade</p>	<p><b>Preencha na altura da instalação para futura referência.</b></p> <p>Modelo nº – _____</p> <p>Nº de série – _____</p> <p>Opcões da máquina – _____</p> <p>Vendedor – _____</p> <p>Telefone do vendedor – _____</p> <p>Número de ID do cliente – _____</p> <p>Data de instalação – _____</p>
-------------	--	--

<b>RU</b>	<p><b>КАК ЗАКАЗАТЬ ЗАПЧАСТИ - См. схему ниже.</b></p> <p>Используйте только запчасти, поставляемые компанией TENNANT или их аналоги. Запасные части и расходные материалы можно заказать в режиме онлайн, телефоном, факсом или электронной почтой.</p> <p>Для своевременной доставки следуйте описанным ниже инструкциям.</p> <ol style="list-style-type: none"> <li>1. <b>(A)</b> Укажите модель машины.</li> <li>2. <b>(B)</b> Укажите серийный номер машины, обозначенный на табличке технических данных.</li> <li>3. <b>(C)</b> Удостоверьтесь, что надлежащий серийный номер перечислен в списке запчастей.</li> <li>4. Укажите номер детали и нужное количество. Не используйте номера страниц или ссылок.</li> <li>5. Укажите свое имя, название компании, идентификационный номер покупателя, расчетный адрес и адрес доставки, телефонный номер и номер заказа на покупку.</li> <li>6. Укажите подробные сведения о доставке.</li> </ol> <hr/> <p><b>(D)</b>    ▽ – означает узел                 ▲ – обозначает деталь узла</p>	<p><b>Во время установки заполните, пожалуйста, эти сведения для того, чтобы ссылаться в дальнейшем.</b></p> <p>Модель Э – _____</p> <p>Серийный Э – _____</p> <p>Опции машины – _____</p> <p>Торговый представитель – _____</p> <p>Телефон торгового представителя – _____</p> <p>Идент. номер покупателя – _____</p> <p>Дата установки – _____</p>
-----------	--	--

<b>SE</b>	<p><b>BESTÄLLNING AV RESERVDELAR – Se ovanstående schema.</b></p> <p>Använd endast delar från Tennant Company eller likvärdiga. Delar och material kan beställas online, telefoniskt, per fax eller post.</p> <p>Följ nedanstående steg för en snabb leverans.</p> <ol style="list-style-type: none"> <li><b>(A)</b> Identifiera maskinens modell.</li> <li><b>(B)</b> Identifiera maskinens serienummer på typskylten.</li> <li><b>(C)</b> Kontrollera att rätt serienummer används från delistan.</li> <li>Identifiera artikelnumret och mängden. Beställ inte med hjälp av sido- eller referensnummer.</li> <li>Uppge ditt namn, företagets namn, kundens ID-nummer, faktura- och leveransadress, telefonnummer och ordernumret vid inköp.</li> <li>Ge detaljerade transportanvisningar.</li> </ol>	<p><b>Fyll i vid installation och spar för framtida bruk.</b></p> <p>Modellnr. – _____</p> <p>Serienr. – _____</p> <p>Tilvalsutrustning – _____</p> <p>Försäljare – _____</p> <p>Försäljarens tel.nr. – _____</p> <p>Kundnummer – _____</p> <p>Installationsdatum – _____</p>
	<p><b>(D)</b> ▽ – identifierar en modul ▲ – identifierar delar som ingår i en modul</p>	

<b>SK</b>	<p><b>POSTUP PRI OBJEDNÁVANÍ ČASTÍ - Pozri vyššie uvedený diagram.</b></p> <p>Využívajte výhradne dielce dodané spoločnosťou TENNANT, alebo ich ekvivalenty. Dielce a položky je možné objednať online, telefonicky, faxom, alebo poštou.</p> <p>Na zabezpečenie promptného doručenia sa riadte nasledovnými krokmi.</p> <ol style="list-style-type: none"> <li><b>(A)</b> Identifikujte model stroja.</li> <li><b>(B)</b> Z etikety s údajmi identifikujte sériové číslo stroja.</li> <li><b>(C)</b> Ubezpečte sa, že ste zadali správne sériové číslo zo zoznamu dielcov.</li> <li>Identifikujte číslo dielu a množstvo. Neobjednávajte pomocou čísel strán, alebo referenčných čísel.</li> <li>Zadajte Vaše meno, meno spoločnosti, ID číslo zákazníka, fakturačnú a prepravnú adresu, telefónne číslo a objednávacie číslo dielu.</li> <li>Uvedte podrobné prepravné pokyny.</li> </ol>	<p><b>Vypíšte prosím pri inštalácii pre prípad potreby v budúcnosti.</b></p> <p>č. modelu – _____</p> <p>Sériové č. – _____</p> <p>Zvláštne príslušenstvo stroja – _____</p> <p>Obchodné zastúpenie – _____</p> <p>Obch. zastúpenie tel. č. – _____</p> <p>ID č. zákazníka – _____</p> <p>Dátum inštalácie – _____</p>
	<p><b>(D)</b> ▽ – identifikuje sadu ▲ – identifikuje časti sady</p>	

<b>SL</b>	<p><b>NAROČANJE NADOMESTNIH DELOV - glejte zgornjo sliko.</b></p> <p>Uporabljajte samo originalne nadomestne dele Tennant ali enakovredne dele. Dele in potrošni material lahko naročite prek spleta, po telefonu, faksu ali pošti.</p> <p>Za zagotovitev čimbolj hitre dostave sledite spodnjim navodilom.</p> <ol style="list-style-type: none"> <li><b>(A)</b> Ugotovite model stroja.</li> <li><b>(B)</b> Na ploščici s podatki poiščite serijsko številko stroja.</li> <li><b>(C)</b> Poskrbite, da na seznamu nadomestnih delov poiščete pravilno serijsko številko.</li> <li>Poiščite številko dela in potrebno količino. Pri naročilih ne navajajte strani ali referenčne številke.</li> <li>Navedite svoje ime, ime podjetja, ID številko stranke, naslova za dostavo in izdajo računa, telefonsko številko in številko naročila.</li> <li>Navedite podrobna navodila za dostavo.</li> </ol>	<p><b>Prosimo, da ob vgradnji izpolnite te podatke, da vam bodo v prihodnje na voljo.</b></p> <p>Št. modela – _____</p> <p>Serijska številka – _____</p> <p>Dodatna oprema stroja – _____</p> <p>Prodajni predstavnik – _____</p> <p>Telefonska št. prodajnega predstavnika – _____</p> <p>Številka stranke – _____</p> <p>Datum vgradnje – _____</p>
	<p><b>(D)</b> ▽ – označuje sklop ▲ – označuje dele sklopa</p>	

<b>TR</b>	<p><b>PARÇALARIN SİPARİŞ EDİLMESİ - Yukarıdaki şemaya bakın.</b></p> <p>Yalnızca TENNANT Company'den sağlanan veya eşdeğerde parçalar kullanın. Parça veya sarf malzemeleri çevrimiçi olarak, telefonla, faksla veya postayla sipariş edilebilir.</p> <p>Zamanında teslimatı sağlamak için aşağıdaki adımları izleyin.</p> <ol style="list-style-type: none"> <li><b>(A)</b> Makine modelini belirtin.</li> <li><b>(B)</b> Veri etiketinden makine seri numarasını belirtin.</li> <li><b>(C)</b> Parça listesinden uygun seri numarasının kullanıldığından emin olun.</li> <li>Parça numarasını ve miktarını belirtin. Sayfa veya referans numaralarını kullanarak sipariş vermeyin.</li> <li>Adınızı, şirketinizin adını, müşteri kimlik numaranızı, faturalama ve sevkiyat adreslerini, telefon numarasını ve satın alma siparişi numarasını belirtin.</li> <li>Ayrıntılı sevkiyat talimatlarını belirtin.</li> </ol>	<p><b>İleri tarihlerde başvurmak için lütfen kurulum sırasında doldurun.</b></p> <p>Model No. - _____</p> <p>Seri No. - _____</p> <p>Makine Seçenekleri - _____</p> <p>Satış Temsilcisi - _____</p> <p>Satış Temsilcisi telefon no. - _____</p> <p>Müşteri Kimlik Numarası - _____</p> <p>Kurulum Tarihi - _____</p>
	<p><b>(D)</b> ▽ – bir tertibatı belirtir ▲ – tertibattaki parçaları belirtir</p>	



---

<b>Contents</b>	<b>Page</b>
Fig. 1 – Seat, Shroud, and Hopper Group . . . . .	2
Fig. 2 – Steering and Brake Group . . . . .	4
Fig. 3 – Rear Drive Wheel Group . . . . .	6
Fig. 4 – Hopper Cover and Brush Compartment Group . . . . .	8
Fig. 5 – Vacuum Fan and Filter Group . . . . .	10
Fig. 6 – Right Side Brush Group . . . . .	12
Fig. 7 – Left Side Brush Kit . . . . .	14
Fig. 8 – Main Brush Group . . . . .	16
Fig. 9 – Main Brush Lift Group . . . . .	18
Fig. 10 – Debris Flapper Group . . . . .	20
Fig. 11 – Electrical Group . . . . .	22
Fig. 12 – Battery and Charger Group . . . . .	24
Fig. 13 – Electrical Schematic . . . . .	26
Fig. 14 – Documentation Group . . . . .	27

Fig. 1 - Seat, Shroud, and Hopper Group

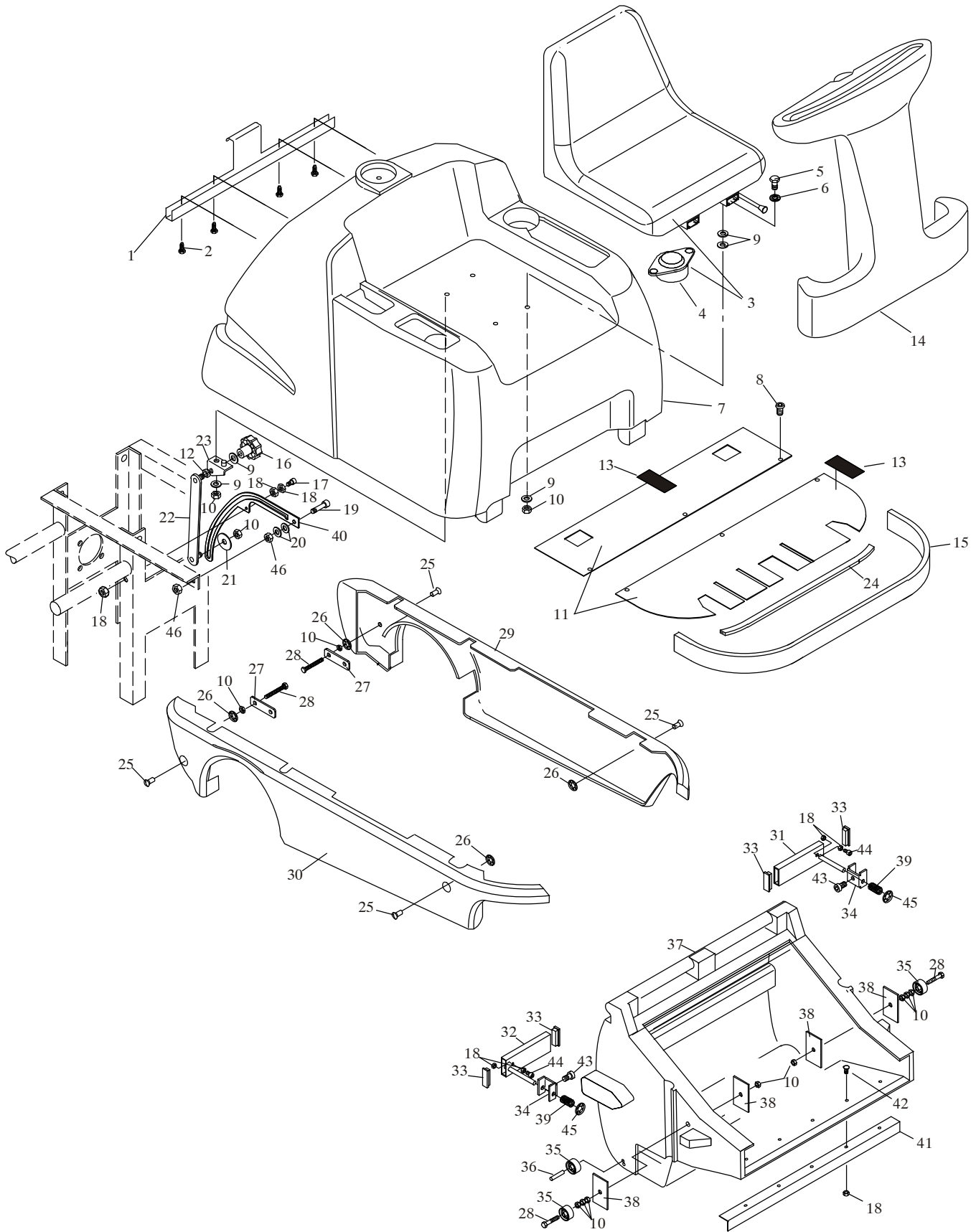

**Fig. 1 – Seat, Shroud, and Hopper Group**

Ref.	Part No.	Serial Number	Description	Qty.
1	384661	(000000–	) Channel	1
2	384569	(000000–	) Screw	4
▽ 3	384665	(000000–	) Seat	1
▲ 4	384878	(000000–	) Contact, Seat	1
5	384620	(000000–	) Screw, M8 X 20mm	4
6	384832	(000000–	) Washer	4
7	384503	(000000–	) Cover, Main	1
8	384796	(000000–	) Screw, M6 X 12mm	6
9	384577	(000000–	) Washer, Flat, M8.4	14
10	384591	(000000–	) Nut, M8	16
11	384527	(000000–	) Plate	1
12	384761	(000000–	) Spacer, Thrd	1
13	384528	(000000–	) Label, Non-Skid	2
14	384504	(000000–	) Cover, Steering	1
15	384513	(000000–	) Cover, Front	1
16	384840	(000000–	) Handle	1
17	384610	(000000–	) Screw, M6 X 25mm	1
18	384587	(000000–	) Nut, M6	12
19	384643	(000000–	) Screw, M10 X 35mm	1
20	384572	(000000–	) Washer, Flat, M10	2
21	384570	(000000–	) Washer, Flat, M8.4	1
22	384508	(000000–	) Bar, Adj, Main Cover	1
23	384509	(000000–	) Plate, Sppt	1
24	384667	(000000–	) Gasket, 0.72m	1
25	384636	(000000–	) Nut, M8	4
26	384650	(000000–	) Washer, Lock	4
27	384679	(000000–	) Plate, Cover	2
28	384624	(000000–	) Screw, M8 X 75mm	4
29	384511	(000000–	) Cover, Lh	1
30	384512	(000000–	) Cover, Rh	1
31	384674	(000000–	) Stop, Hppr, Lh	1
32	384675	(000000–	) Stop, Hppr, Rh	1
33	384676	(000000–	) Cover, Collector	4
34	384677	(000000–	) Plate, U, Hppr	2
35	384673	(000000–	) Wheel, Guide	4
36	384654	(000000–	) Shaft, Wheel	2
37	384516	(000000–	) Hopper	1
38	384672	(000000–	) Plate	4
39	384678	(000000–	) Spring	2
40	384510	(000000–	) Plate [SI]	1
41	384800	(000000–	) Bar, Sppt, Hppr	1
42	384815	(000000–	) Screw	5
43	384606	(000000–	) Screw, M8 X 12mm	2
44	384598	(000000–	) Screw, M6 X 16mm	2
45	384652	(000000–	) Washer, Lock	2
46	384586	(000000–	) Nut, M10	2

**Fig. 2 – Steering and Brake Group**

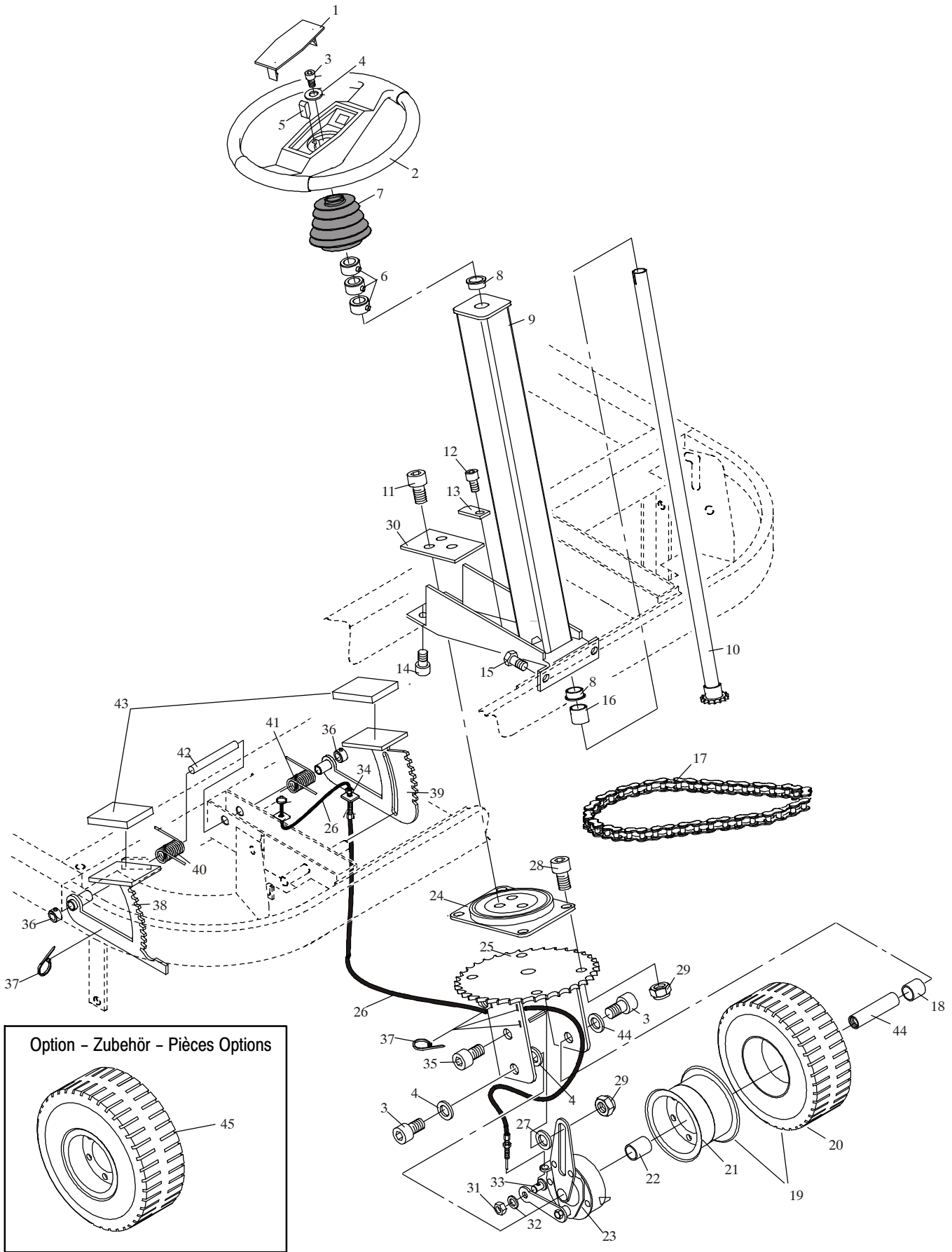

**Option – Zubehör – Pièces Options**

45

**Fig. 2 – Steering and Brake Group**

Ref.	Part No.	Serial Number	Description	Qty.	
1	384844	(000000–	) Cover, Wheel, Steering	1	
2	384712	(000000–	) Wheel, Steering	1	
3	384605	(000000–	) Screw, M12 X 30mm	3	
4	384576	(000000–	) Washer, Flat	4	
5	384637	(000000–	) Key, 6mm X 6mm X 25mm	4	
6	384597	(000000–	) Sleeve, Adj	3	
7	1012437	(000000–	) Bellows, Shaft, Steering	1	
8	384714	(000000–	) Bearing, Slide	2	
9	384715	(000000–	) Frame, Steering	1	
10	384716	(000000–	) Column, Steering	1	
11	384736	(000000–	) Screw, M12 X 20mm	3	
12	384606	(000000–	) Screw, M8 X 12mm	1	
13	384720	(000000–	) Plate, Eccentric	1	
14	384600	(000000–	) Screw, M8 X 25mm	3	
15	384620	(000000–	) Screw, M8 X 20mm	2	
16	384718	(000000–	) Spacer	1	
17	384721	(000000–	) Chain	1	
18	384733	(000000–	) Spacer	1	
▽	19	1048835	(000000–	) Wheel, Front, Non-Marking	1
▲	20	1049282	(000000–	) Tire, Front, non-Marking [S12]	1
▲	21	384892	(000000–	) Rim, Wheel, Front [Set Of 2]	1
22	384734	(000000–	) Spacer	1	
23	384732	(000000–	) Brake	1	
24	384722	(000000–	) 19.57earing, Ball	1	
25	384723	(000000–	) Sprocket	1	
26	384730	(000000–	) Cable, 2mm	1	
27	384572	(000000–	) Washer, Flat, M10	1	
28	384599	(000000–	) Screw, M10 X 25mm	4	
29	384630	(000000–	) Nut, M10	4	
30	384719	(000000–	) Plate, Adj	1	
31	384629	(000000–	) Nut, M6	1	
32	384574	(000000–	) Washer, Flat, M6.4	1	
33	384658	(000000–	) Screw	1	
34	384587	(000000–	) Nut, M6	2	
35	384603	(000000–	) Screw, M10 X 20mm	1	
36	384595	(000000–	) Sleeve, Adj	2	
37	384656	(000000–	) Tie, Cable	4	
38	384728	(000000–	) Pedal, Accelerator	1	
39	384727	(000000–	) Pedal, Brake	1	
40	384846	(000000–	) Spring	1	
41	384726	(000000–	) Spring	1	
42	384709	(000000–	) Shaft, Pedal, 10mm X 130mm	1	
43	384724	(000000–	) Cover, Pedal, Rbr	2	
44	384731	(000000–	) Shaft, Wheel, Front	1	
45	384931	(000000–	) Tire Assy, Blk, Solid (With Rim)	1	
45	384932	(000000–	) Tire Assy, Pneu (Without Rim)	1	

**Fig. 3 – Rear Drive Wheel Group**

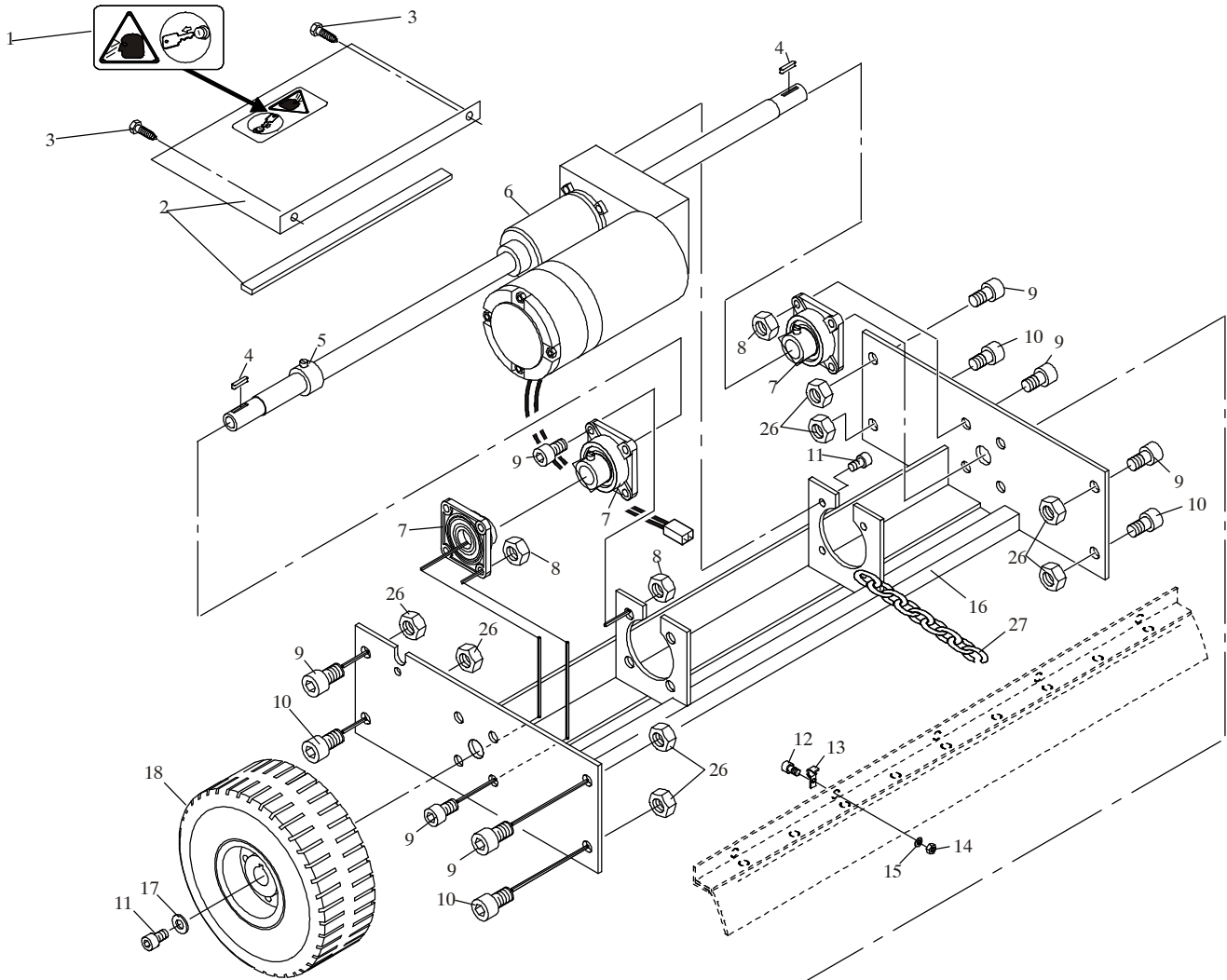

**Option – Zubehör – Pièces Options**

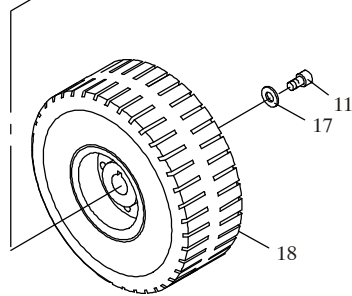
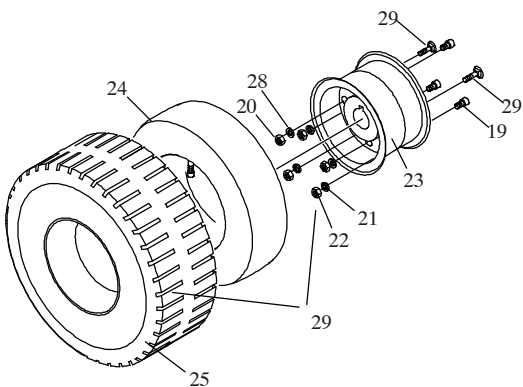

**Fig. 3 – Rear Drive Wheel Group**

Ref.	Part No.	Serial Number	Description	Qty.
1	81561	(000000– )	Label, Hzrd, Hppr Lift, Ce [6200]	1
2	384751	(000000– )	Cover, Motor	1
3	384838	(000000– )	Screw	2
4	384637	(000000– )	Key, 6mm X 6mm X 25mm	2
5	384597	(000000– )	Sleeve, Adj	1
▽ 6	384752	(000000– )	Motor, 24vdc	1
▲	384935	(000000– )	Brush Kit, Motor, Drive [Set Of 4]	1
7	384754	(000000– )	Bearing, Ball	3
8	384590	(000000– )	Nut, M12	12
9	384605	(000000– )	Screw, M12 X 30mm	16
10	384604	(000000– )	Screw, M12 X 25mm	4
11	384598	(000000– )	Screw, M6 X 16mm	6
12	384819	(000000– )	Screw	5
13	384653	(000000– )	Clamp	1
14	384831	(000000– )	Nut	5
15	384839	(000000– )	Washer	5
16	384753	(000000– )	Support, Axle, Rear	1
17	384582	(000000– )	Washer, Flat, M6.6	2
▽ 18	994309	(000000– )	Tire, Foam Filled 260x85	2
▲ 19	384620	(000000– )	Screw, M8 X 20mm	4
▲ 20	384591	(000000– )	Nut, M8	4
▲ 21	384645	(000000– )	Washer, Flat, M6.4	4
▲ 22	384587	(000000– )	Nut, M6	4
▲ 23	384756	(000000– )	Wheel, 03.0	2
▲ 24	384852	(000000– )	Tube, Wheel, Rear	2
25	384536	(000000– )	Tire Assy, Pneu, Non-Marking (Option)	2
26	384632	(000000– )	Nut, M12	8
27	384786	(000000– )	Chain	1
28	384578	(000000– )	Washer, Star	4
29	384817	(000000– )	Screw	4

Fig. 4 – Hopper Cover and Brush Compartment Group

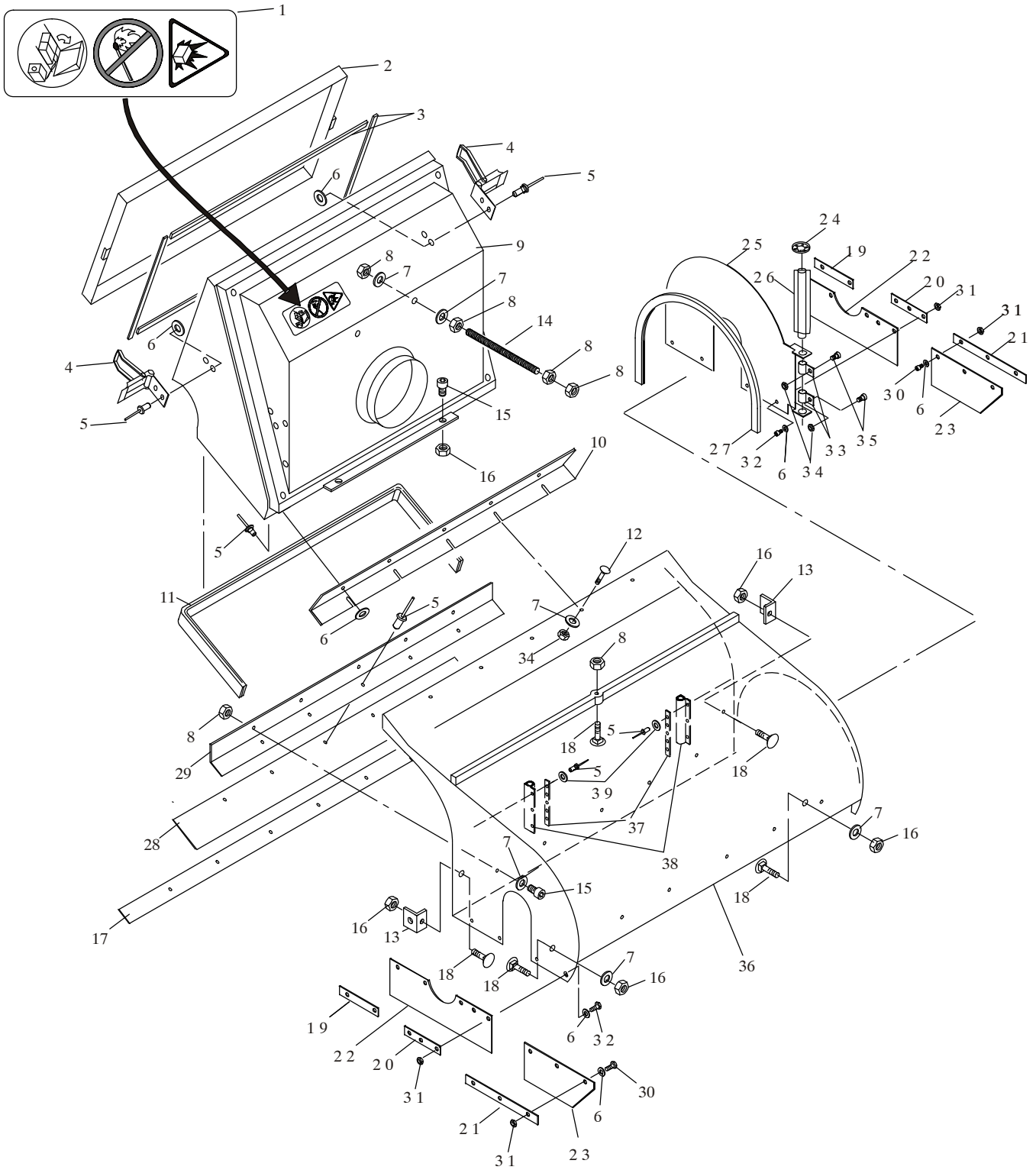
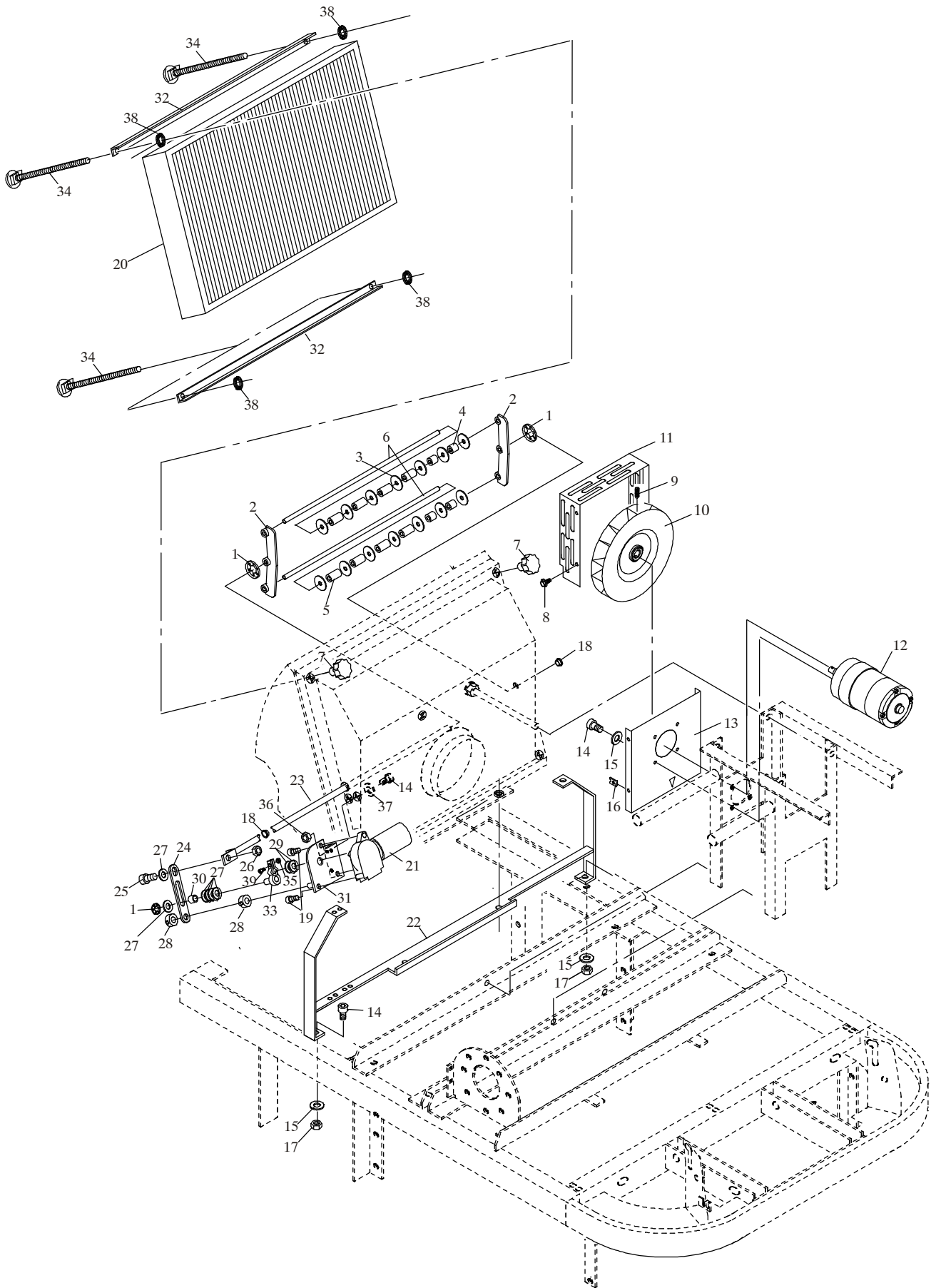



**Fig. 4 – Hopper Cover and Brush Compartment Group**

Ref.	Part No.	Serial Number	Description	Qty.
1	630422	(000000-	) Label, Battery Charge [Textless]	1
2	384803	(000000-	) Cover, Fltr	1
3	384664	(000000-	) Gasket, 1.7mtr	4
4	384804	(000000-	) Clamp Set	2
5	384686	(000000-	) Rivet	20
6	384644	(000000-	) Washer, Flat, M4.3	22
7	384574	(000000-	) Washer, Flat, M6.4	17
8	384587	(000000-	) Nut, M6	14
9	384670	(000000-	) Filterbox	1
10	384802	(000000-	) Bar, Sppt, Roll Cover	1
11	384671	(000000-	) Gasket, Hppr	1
12	384592	(000000-	) Screw, M5 X 16mm	5
13	384682	(000000-	) Plate, Cover, Roll	2
14	384628	(000000-	) Shaft, M6 X 150mm	2
15	384598	(000000-	) Screw, M6 X 16mm	7
16	384629	(000000-	) Nut, M6	6
17	384684	(000000-	) Plate, Flap, Recirculation	1
18	384815	(000000-	) Screw	5
19	384521	(000000-	) Plate, Back	2
20	384520	(000000-	) Plate, Cntr	2
21	384518	(000000-	) Plate, Cover, Gasket Rlr	2
22	384522	(000000-	) Skirt, Side, Rear	2
23	384519	(000000-	) Cover, Rlr, Gasket	2
24	384841	(000000-	) Washer, Lock	1
25	384551	(000000-	) Door, Brush	1
26	384548	(000000-	) Shaft	1
27	384668	(000000-	) Gasket, Cover, Brush, 0.92m	1
28	384685	(000000-	) Gasket, Flap, Recirculation	1
29	384683	(000000-	) Flap, Recirculation	1
30	384619	(000000-	) Screw, M4 X 16mm	6
31	384633	(000000-	) Nut, M4	16
32	384826	(000000-	) Screw	8
33	384877	(000000-	) Clamp	8
34	384831	(000000-	) Nut	2
35	384828	(000000-	) Screw	2
36	384517	(000000-	) Cover, Roll	1
37	384875	(000000-	) Plate	2
38	384876	(000000-	) Gasket, Hppr, Side	2
39	384572	(000000-	) Washer, Flat, M10	2

**Fig. 5 – Vacuum Fan and Filter Group**



**Fig. 5 – Vacuum Fan and Filter Group**

Ref.	Part No.	Serial Number	Description	Qty.
1	384650	(000000–	) Washer, Lock	3
2	384688	(000000–	) Plate, Connecting	2
3	384691	(000000–	) Washer, Cleaner, Fltr	14
4	384692	(000000–	) Spacer	4
5	384693	(000000–	) Spacer	8
6	384689	(000000–	) Shaft, Cleaner, Fltr	2
7	384647	(000000–	) Knob, M6	4
8	384834	(000000–	) Screw	4
9	384614	(000000–	) Screw, M6 X 8mm	2
10	384698	(000000–	) Fan, Vent	1
11	384524	(000000–	) Plate, Cleaner, Fltr	1
▽ 12	384697	(000000–	) Motor, 24vdc	1
▲	384933	(000000–	) Brush Kit, Motor [Set Of 4]	1
13	384525	(000000–	) Plate, Guard, Fan	1
14	384598	(000000–	) Screw, M6 X 16mm	10
15	384574	(000000–	) Washer, Flat, M6.4	6
16	384835	(000000–	) Nut, Snap On	4
17	384629	(000000–	) Nut, M6	2
18	384655	(000000–	) Bearing, Slide	2
19	384822	(000000–	) Screw	3
20	384696	(000000–	) Filter, Dust, Pye	1
21	384700	(000000–	) Motor, Cleaner, Fltr, 24vdc	1
22	384705	(000000–	) Support, Box, Fltr	1
23	384699	(000000–	) Shaft, Main, Cleaner, Fltr	1
24	384703	(000000–	) Plate, Cleaner, Fltr	1
25	384599	(000000–	) Screw, M10 X 25mm	1
26	384630	(000000–	) Nut, M10	1
27	384572	(000000–	) Washer, Flat, M10	4
28	384595	(000000–	) Sleeve, Adj	2
29	384581	(000000–	) Washer, Flat, M10.5	6
30	384805	(000000–	) Bearing	1
31	384702	(000000–	) Support, Cleaner, Fltr	1
32	384694	(000000–	) Plate, Fltr, Dust	2
33	384704	(000000–	) Sleeve, Adj	1
34	384816	(000000–	) Screw	4
35	384831	(000000–	) Nut	1
36	384587	(000000–	) Nut, M6	2
37	384645	(000000–	) Washer, Flat, M6.4	2
38	384843	(000000–	) Screw, Retainer	4
39	384818	(000000–	) Screw	1

**Fig. 6 – Right Side Brush Group**

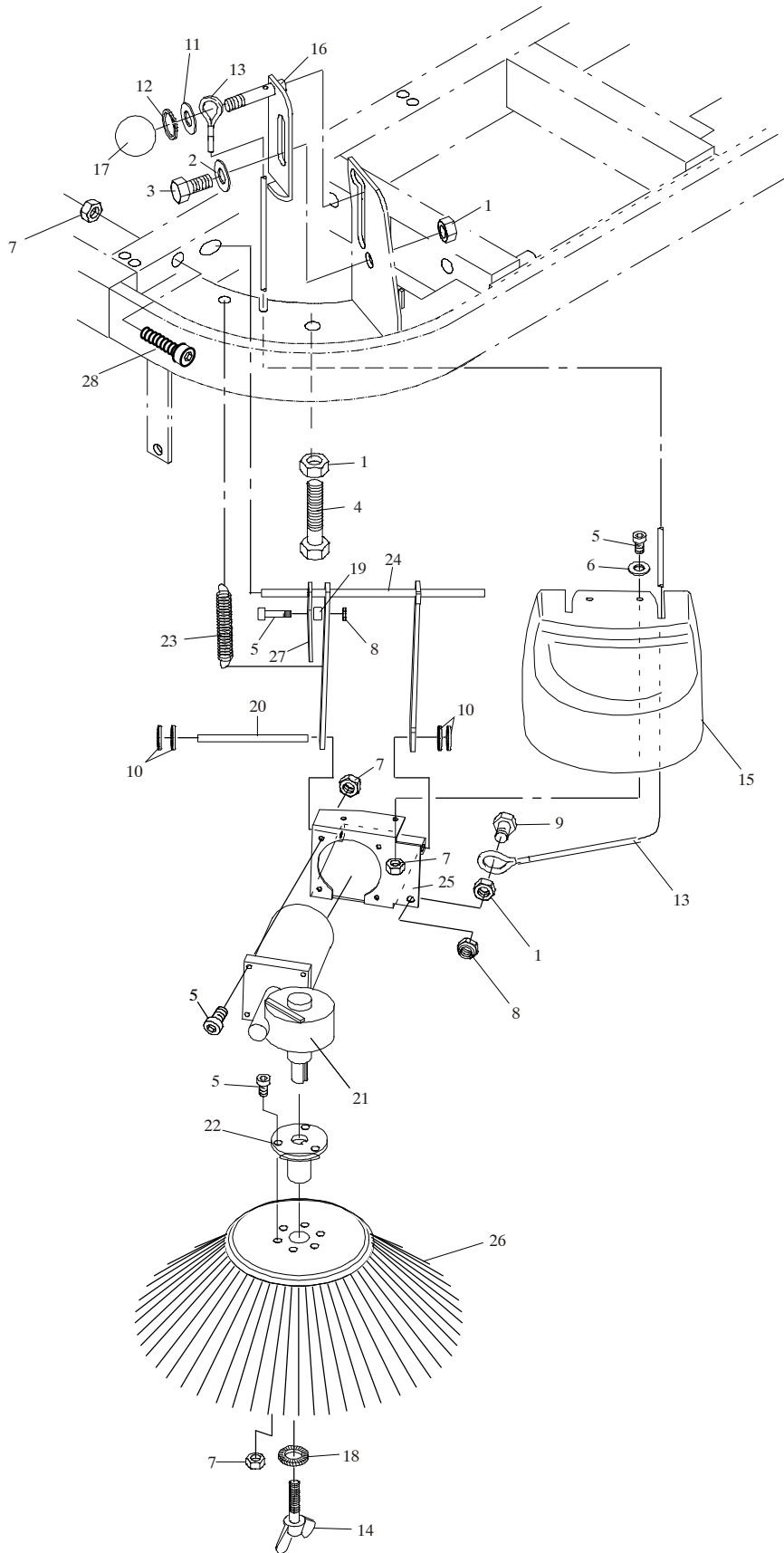

**Fig. 6 – Right Side Brush Group**

	<b>Ref.</b>	<b>Part No.</b>	<b>Serial Number</b>	<b>Description</b>	<b>Qty.</b>
▽		9003462	(000000–	) Brush Kit, Side, Rh, Ci [S12]	1
▲	1	384591	(000000–	) Nut, M8	3
▲	2	384571	(000000–	) Washer, Flat, M10.5	1
▲	3	384620	(000000–	) Screw, M8 X 20mm	1
▲	4	384622	(000000–	) Screw, M8 X 50mm	1
▲	5	384598	(000000–	) Screw, M6 X 16mm	10
▲	6	384645	(000000–	) Washer, Flat, M6.4	2
▲	7	384587	(000000–	) Nut, M6	11
▲	8	384629	(000000–	) Nut, M6	2
▲	9	384600	(000000–	) Screw, M8 X 25mm	1
▲	10	384650	(000000–	) Washer, Lock	4
▲	11	384572	(000000–	) Washer, Flat, M10	1
▲	12	384814	(000000–	) Ring, Snap	1
▲	13	384770	(000000–	) Cable	1
▲	14	384812	(000000–	) Bolt, Wing, M6 X 16	1
▲	15	384515	(000000–	) Cover, Motor, Side Brush	1
▲	16	384772	(000000–	) Plate, Adj, Rh Side Brush	1
▲	17	384711	(000000–	) Handle	1
▲	18	384833	(000000–	) Washer	1
▲	19	384810	(000000–	) Bushing	1
▲	20	384779	(000000–	) Shaft	1
▲▽	21	384776	(000000–	) Motor, Brush, Rh, 24vdc	1
▲▲		384936	(000000–	) Brush Kit, Motor [Set Of 4]	1
▲	22	384780	(000000–	) Adapter, Brush	1
▲	23	384760	(000000–	) Spring	2
▲	24	384773	(000000–	) Mount, Brush, Lh	1
▲	25	384778	(000000–	) Plate, Motor, Rh Side Brush	1
▲	26	384782	(000000–	) Brush, Disk, Swp, 16.0d 406mm, Std	1
▲	27	384567	(000000–	) Stop, Brush, Side	1
▲	28	06948	(000000–	) Screw, Hex, M6 X 1.0 X 45, 8.8	2

**Fig. 7 - Left Side Brush Kit**

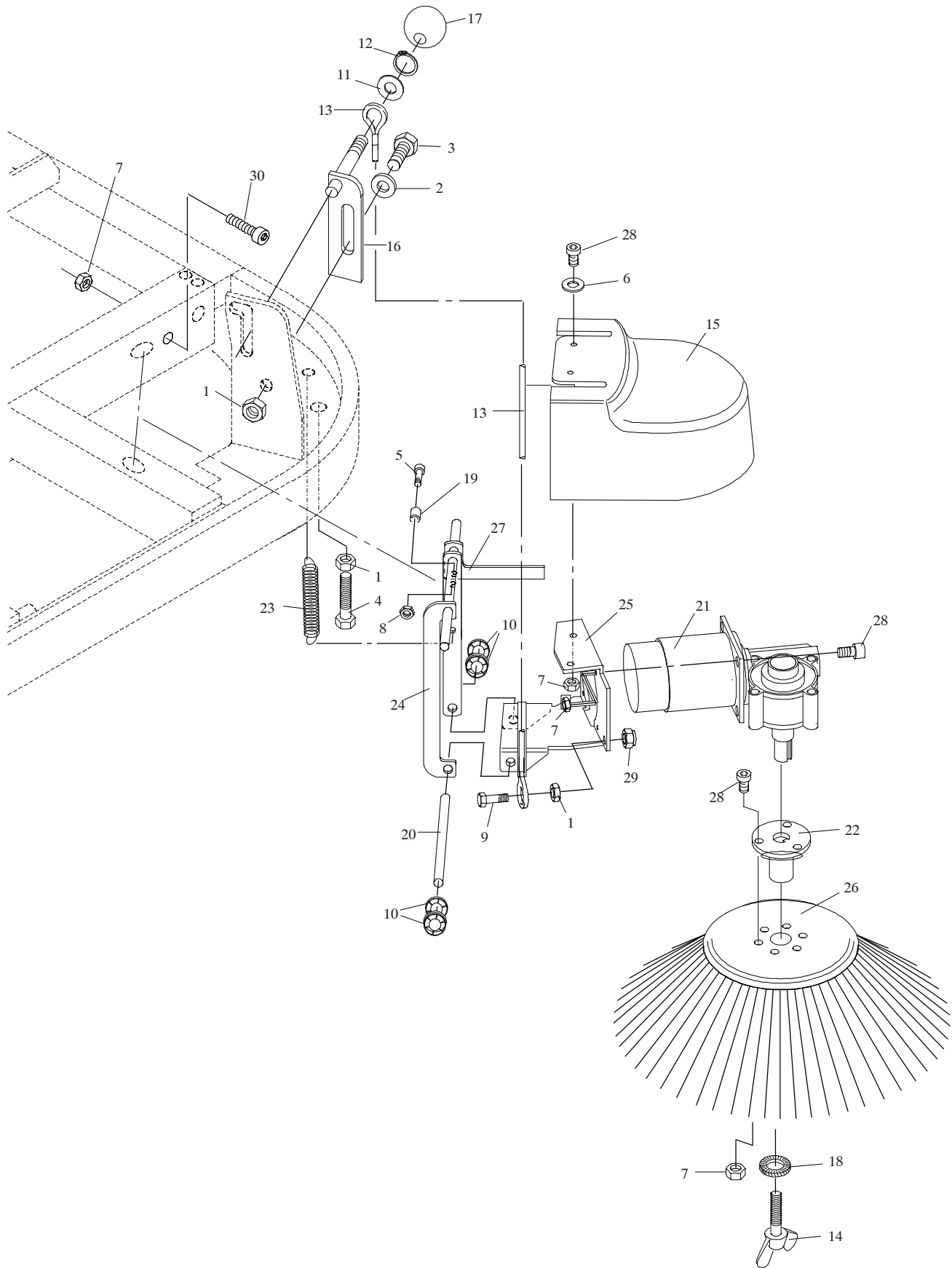

**Fig. 7 – Left Side Brush Kit**

	<b>Ref.</b>	<b>Part No.</b>	<b>Serial Number</b>	<b>Description</b>	<b>Qty.</b>
▽		995434	(000000–	) Brush Kit, Side, Lh, Ci [S12]	1
▲	1	384591	(000000–	) Nut, M8	3
▲	2	384571	(000000–	) Washer, Flat, M10.5	1
▲	3	384620	(000000–	) Screw, M8 X 20mm	1
▲	4	384622	(000000–	) Screw, M8 X 50mm	1
▲	5	384598	(000000–	) Screw, M6 X 16mm	1
▲	6	384645	(000000–	) Washer, Flat, M6.4	2
▲	7	384587	(000000–	) Nut, M6	11
▲	8	384629	(000000–	) Nut, M6	1
▲	9	384600	(000000–	) Screw, M8 X 25mm	1
▲	10	384650	(000000–	) Washer, Lock	4
▲	11	384572	(000000–	) Washer, Flat, M10	1
▲	12	384814	(000000–	) Ring, Snap	1
▲	13	384770	(000000–	) Cable	1
▲	14	384812	(000000–	) Bolt, Wing, M6 X 16	1
▲	15	384515	(000000–	) Cover, Motor, Side Brush	1
▲	16	384771	(000000–	) Plate, Adj, Lh Side Brush	1
▲	17	384711	(000000–	) Handle	1
▲	18	384833	(000000–	) Washer	1
▲	19	384810	(000000–	) Bushing	1
▲	20	384779	(000000–	) Shaft	1
▲▽	21	384775	(000000–	) Motor, Brush, Lh, 24vdc	1
▲▲		384936	(000000–	) Brush Kit, Motor [Set Of 4]	1
▲	22	384780	(000000–	) Adapter, Brush	1
▲	23	384760	(000000–	) Spring	2
▲	24	384774	(000000–	) Mount, Brush, 4hole	1
▲	25	384777	(000000–	) Plate, Motor, Lh Side Brush	1
▲	26	384782	(000000–	) Brush, Disk, Swp, 16.0d 406mm, Std	1
▲	27	384567	(000000–	) Stop, Brush, Side	1
▲	28	384598	(000000–	) Screw, M6 X 16mm	9
▲	29	384634	(000000–	) Nut, M8	1
▲	30	06948	(000000–	) Screw, Hex, M6 X 1.0 X 45, 8.8	2
▲		384656	(000000–	) Tie, Cable	2

Fig. 8 – Main Brush Group

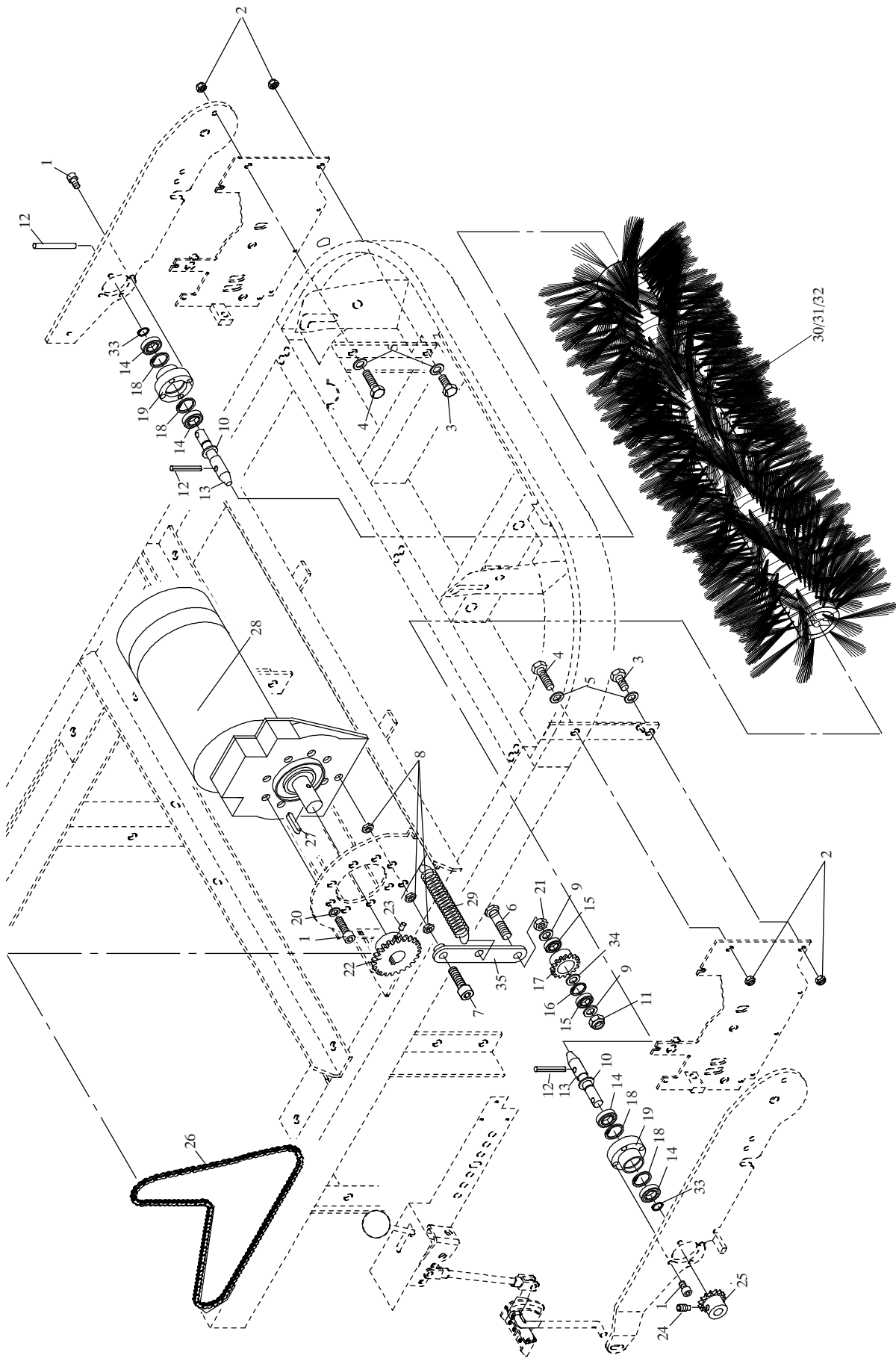
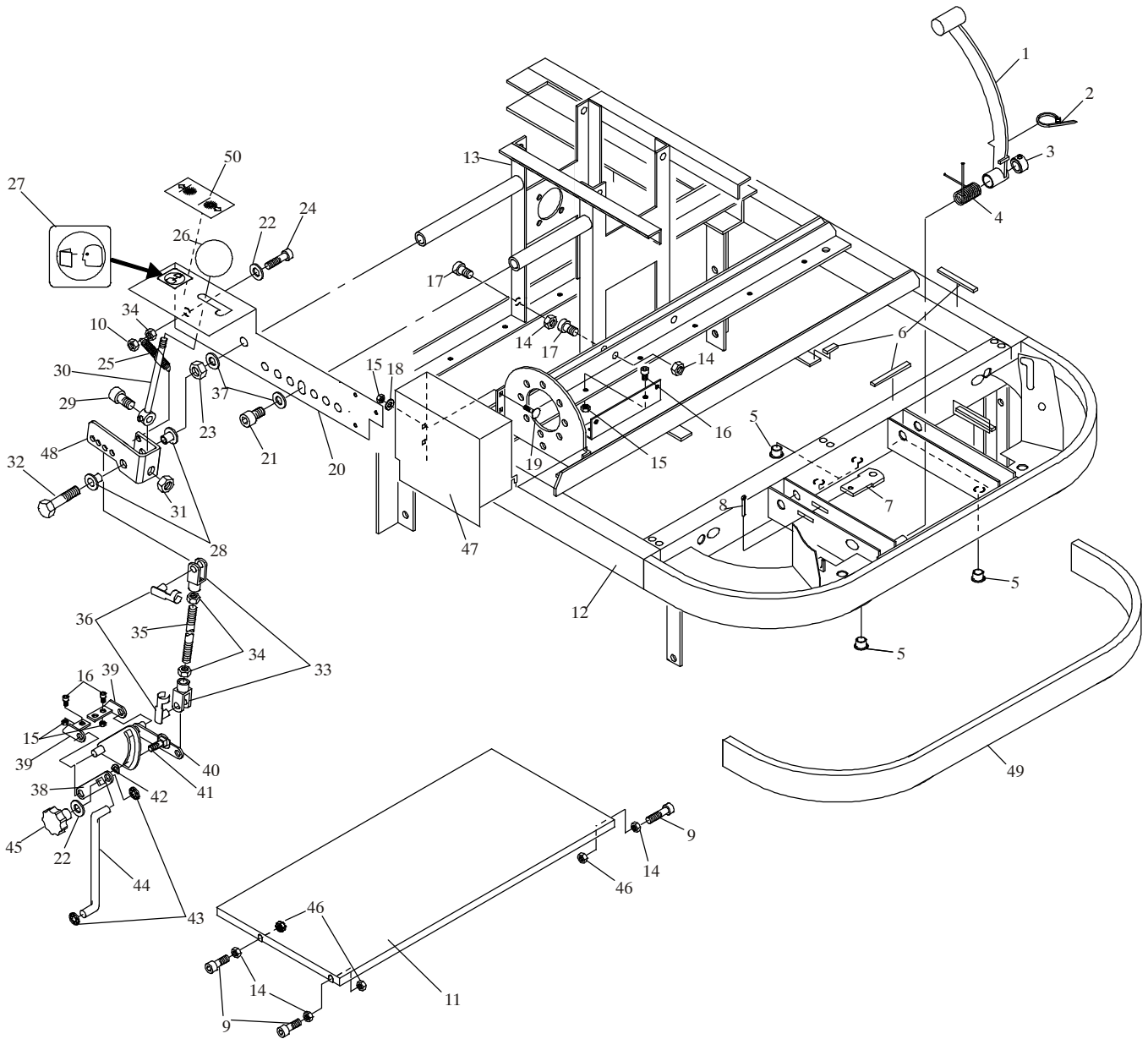



**Fig. 8 – Main Brush Group**

Ref.	Part No.	Serial Number	Description	Qty.	
1	384598	(000000–	) Screw, M6 X 16mm	16	
2	384634	(000000–	) Nut, M8	4	
3	384620	(000000–	) Screw, M8 X 20mm	2	
4	384827	(000000–	) Screw	2	
5	384577	(000000–	) Washer, Flat, M8.4	4	
6	384627	(000000–	) Screw, M10 X 50mm	1	
7	384609	(000000–	) Screw, M8 X 40mm	1	
8	384591	(000000–	) Nut, M8	3	
9	384572	(000000–	) Washer, Flat, M10	2	
10	384766	(000000–	) Ring, Snap	2	
11	384630	(000000–	) Nut, M10	1	
12	384638	(000000–	) Sleeve	3	
13	384765	(000000–	) Shaft, Drive, Brush	2	
14	384648	(000000–	) Bearing, Ball, Main Brush	4	
15	384646	(000000–	) Bearing, Ball	2	
16	384585	(000000–	) Ring, Snap	1	
17	384758	(000000–	) Sprocket	1	
18	384584	(000000–	) Ring, Snap	4	
19	384764	(000000–	) Support, Brg, Ball	2	
20	384574	(000000–	) Washer, Flat, M6.4	8	
21	384586	(000000–	) Nut, M10	1	
22	384552	(000000–	) Sprocket	1	
23	384614	(000000–	) Screw, M6 X 8mm	2	
24	384615	(000000–	) Screw, M10 X 16mm	1	
25	384767	(000000–	) Sprocket	1	
26	384759	(000000–	) Chain	1	
27	384637	(000000–	) Key, 6mm X 6mm X 25mm	1	
▽	28	384757	(000000–	) Motor, Brush, Main, 24vdc, 220vac	1
▲		384934	(000000–	) Brush Kit, Motor, [Set Of 4]	1
	29	9007178	(000000–	) Spring, Chain Tightener [S12]	1
30	384769	(000000–	) Brush, Swp, 28l 700mm, Pyp, Std	1	
31	384879	(000000–	) Brush, Swp, 28l 700mm, Dr, Pyp	1	
32	384880	(000000–	) Brush, Swp, 28l 700mm, Nat Fbr	1	
33	384583	(000000–	) Ring, Snap	2	
34	384581	(000000–	) Washer, Flat, M10.5	1	
35	384557	(000000–	) Arm, Tens, Chain	1	

Fig. 9 – Main Brush Lift Group



**Fig. 9 – Main Brush Lift Group**

Ref.	Part No.	Serial Number	Description	Qty.
1	384707	(000000– )	Lever, Brake, Parking	1
2	384656	(000000– )	Tie, Cable	1
3	384595	(000000– )	Sleeve, Adj	1
4	384708	(000000– )	Spring	1
5	384791	(000000– )	Nut	4
6	384663	(000000– )	Gasket, 1.5cm	4
7	384798	(000000– )	Support, Cable, Brake	1
8	384795	(000000– )	Pin, Split	1
9	384824	(000000– )	Screw	4
10	384634	(000000– )	Nut, M8	1
11	384523	(000000– )	Cover, Int	1
12	384526	(000000– )	Frame, Main	1
13	384706	(000000– )	Frame, Seat	1
14	384587	(000000– )	Nut, M6	8
15	384831	(000000– )	Nut	6
16	384819	(000000– )	Screw	7
17	384598	(000000– )	Screw, M6 X 16mm	4
18	384839	(000000– )	Washer	2
19	384592	(000000– )	Screw, M5 X 16mm	2
20	384544	(000000– )	Panel, Instmt	1
21	384736	(000000– )	Screw, M12 X 20mm	4
22	384576	(000000– )	Washer, Flat	4
23	384590	(000000– )	Nut, M12	1
24	384823	(000000– )	Screw	2
25	384808	(000000– )	Spring	1
26	384711	(000000– )	Handle	2
27	33444	(000000– )	Label, Hzrd, Safety Manual,Ce Rep.Bynone	1
28	384807	(000000– )	Bearing	2
29	384820	(000000– )	Screw	1
30	384710	(000000– )	Lever	1
31	384630	(000000– )	Nut, M10	1
32	384821	(000000– )	Screw, M12 X 70mm	1
33	384725	(000000– )	Lever	2
34	384591	(000000– )	Nut, M8	3
35	384830	(000000– )	Shaft, Thrd	1
36	384845	(000000– )	Bolt	2
37	384577	(000000– )	Washer, Flat, M8.4	2
38	384561	(000000– )	Lever	1
39	384559	(000000– )	Plate, Sppt	2
40	384560	(000000– )	Arm, Adj, Main Brush	1
41	384593	(000000– )	Screw, M8 X 20mm	1
42	384738	(000000– )	Washer	1
43	384841	(000000– )	Washer, Lock	2
44	384558	(000000– )	Bar, Push / Pull	1
45	384762	(000000– )	Knob, M8	1
46	384629	(000000– )	Nut, M6	4
47	384553	(000000– )	Plate, Guard, Main Brush Sprkt	1
48	384545	(000000– )	Plate	1
49	384514	(000000– )	Bumper, Front	1
50	384507	(000000– )	Label, Brush, Main	1

Fig. 10 - Debris Flapper Group

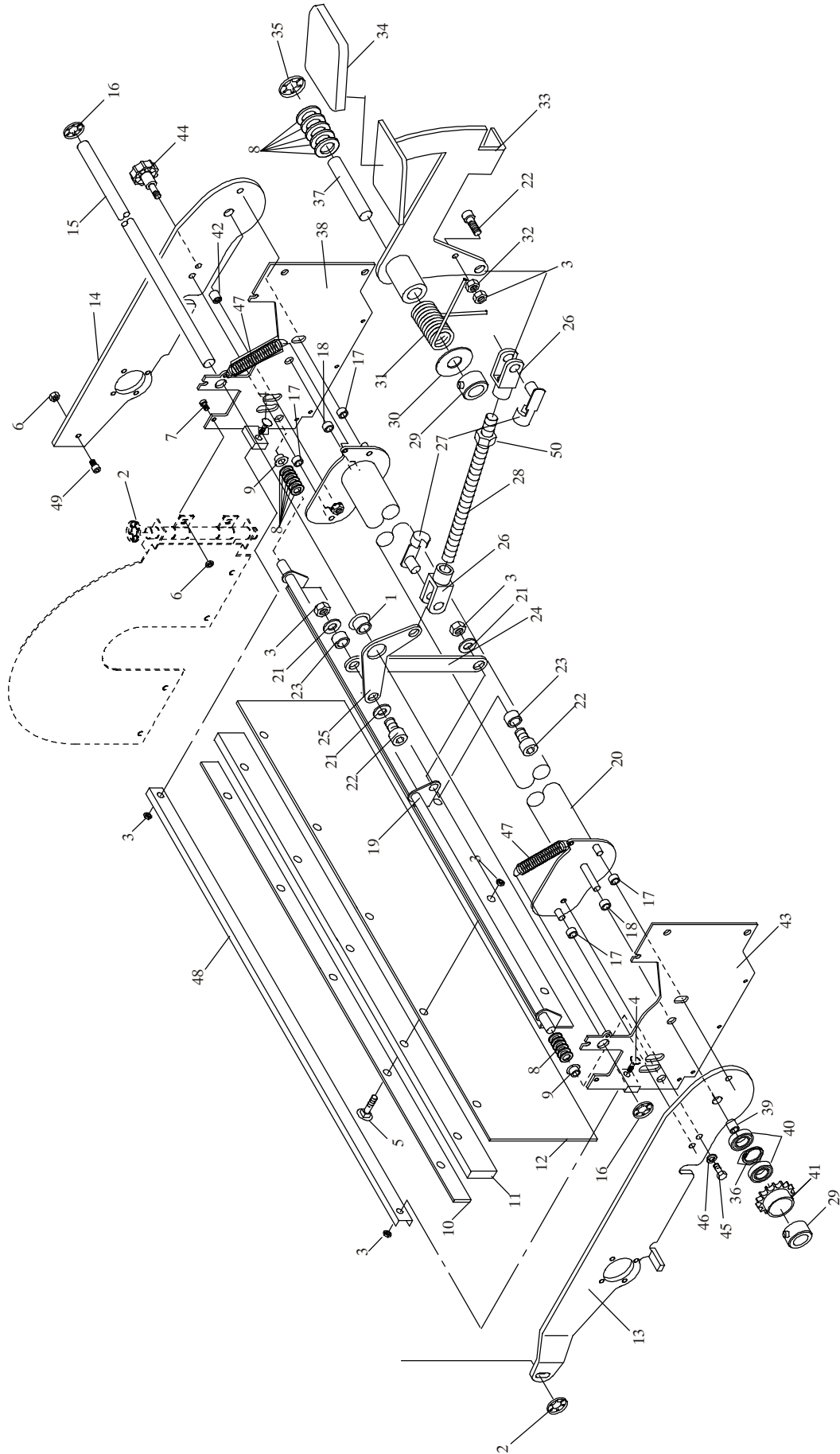

**Fig. 10 – Debris Flapper Group**

<b>Ref.</b>	<b>Part No.</b>	<b>Serial Number</b>	<b>Description</b>	<b>Qty.</b>
1	384540	(000000–	) Bearing, Slide	1
2	384841	(000000–	) Washer, Lock	4
3	384629	(000000–	) Nut, M6	13
4	384815	(000000–	) Screw	2
5	384592	(000000–	) Screw, M5 X 16mm	5
6	384831	(000000–	) Nut	3
7	384828	(000000–	) Screw	3
8	384581	(000000–	) Washer, Flat, M10.5	15
9	384541	(000000–	) Bearing, Slide	2
10	384566	(000000–	) Plate, Trap And Flap	1
11	384565	(000000–	) Skirt, Rbr, Trap And Flap	1
12	384564	(000000–	) Skirt, Rbr, Lrg, Trap And Flap	1
13	384550	(000000–	) Plate, Adj, Lh	1
14	384549	(000000–	) Plate, Adj, Rh	1
15	384539	(000000–	) Shaft	1
16	384842	(000000–	) Washer, Lock	2
17	384555	(000000–	) Spacer	4
18	384809	(000000–	) Bearing	2
19	384563	(000000–	) Support, Trap And Flap	1
20	384554	(000000–	) Support, Hinge, Main Brush	1
21	384574	(000000–	) Washer, Flat, M6.4	3
22	384598	(000000–	) Screw, M6 X 16mm	3
23	384543	(000000–	) Spacer	2
24	384542	(000000–	) Lever, Trap And Flap	1
25	384538	(000000–	) Lever, Trap And Flap	1
26	384725	(000000–	) Lever	2
27	384845	(000000–	) Bolt	2
28	384830	(000000–	) Shaft, Thrd	1
29	384595	(000000–	) Sleeve, Adj	2
30	384813	(000000–	) Washer	1
31	384726	(000000–	) Spring	1
32	384829	(000000–	) Screw	1
33	384537	(000000–	) Pedal, Trap & Flap	1
34	384724	(000000–	) Cover, Pedal, Rbr	1
35	384650	(000000–	) Washer, Lock	1
36	384585	(000000–	) Ring, Snap	1
37	384793	(000000–	) Pin, M10 X 100mm	1
38	384547	(000000–	) Support, Lh	1
39	384556	(000000–	) Spacer	1
40	384646	(000000–	) Bearing, Ball	2
41	384758	(000000–	) Sprocket	1
42	384761	(000000–	) Spacer, Thrd	1
43	384546	(000000–	) Plate	1
44	384762	(000000–	) Knob, M8	1
45	384827	(000000–	) Screw	1
46	384578	(000000–	) Washer, Star	1
47	384808	(000000–	) Spring	2
48	384801	(000000–	) Bar, Sppt, Roll Cover	1
49	384825	(000000–	) Screw	1
50	384591	(000000–	) Nut, M8	1

**Fig. 11 – Electrical Group**

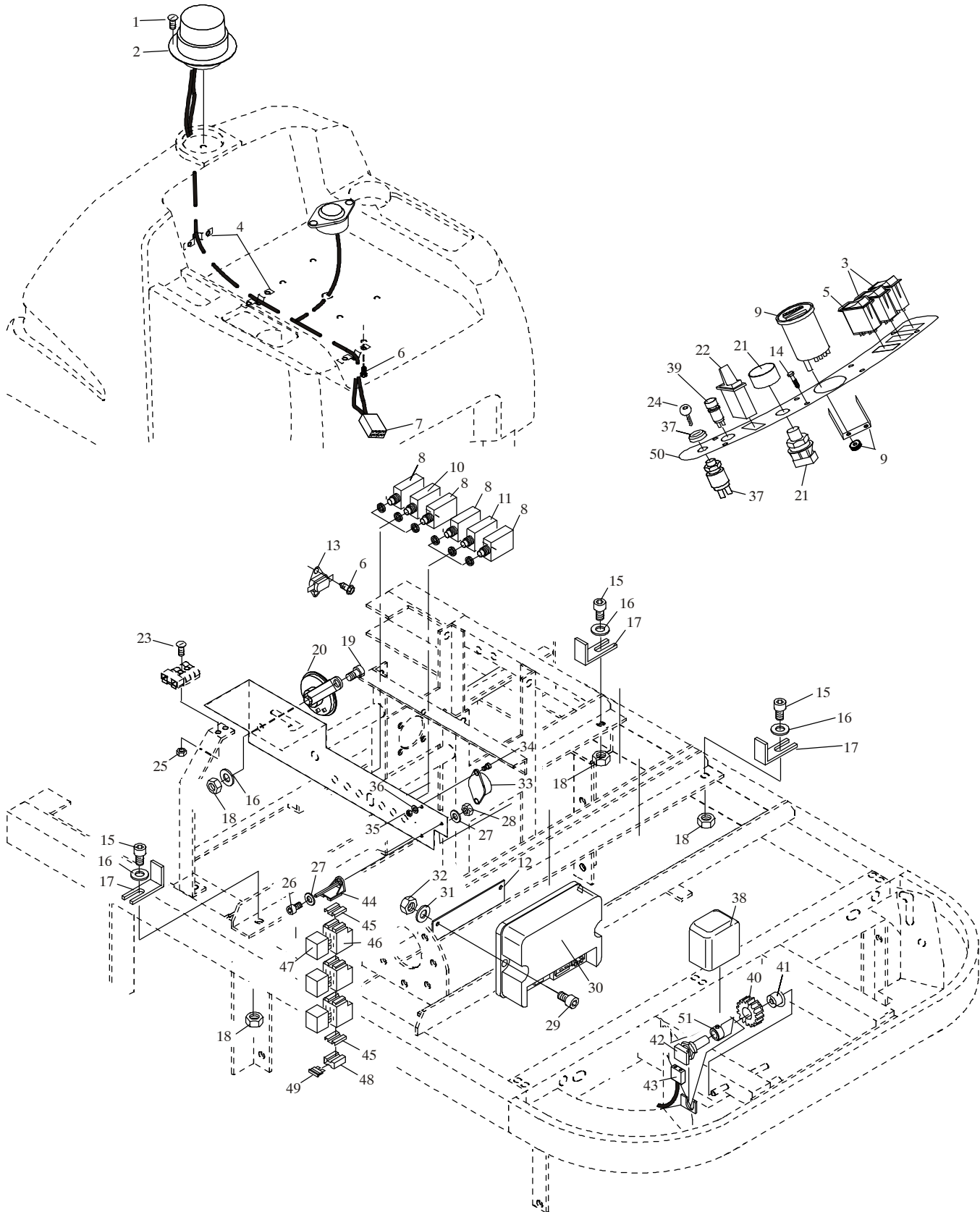

Ref.	Part No.	Serial Number	Description	Qty.
1	384836	(000000– )	Screw	3
2	384535	(000000– )	Light, Warning	1
3	384531	(000000– )	Switch	2
4	384653	(000000– )	Clamp	3
5	384530	(000000– )	Switch	1

**Fig. 11 – Electrical Group**

Ref.	Part No.	Serial Number	Description	Qty.	
6	384837	(000000–	) Screw	8	
7	384659	(000000–	) Contact, Seat	1	
8	384783	(000000–	) Circuitbreaker, 20.0a	4	
9	384744	(000000–	) Gauge, Battery / Hourmeter	1	
9	994308	(000000–	) Gauge, Battery / Hourmeter 24–36 (Only W/ MF Battery)	3	
10	384853	(000000–	) Circuitbreaker, 25.0a	1	
11	384501	(000000–	) Circuitbreaker, 45.0a	1	
12	384579	(000000–	) Plate	1	
13	367679	(000000–	) Switch, Thermal, 160deg, Spdt	1	
14	384797	(000000–	) Screw, Tap, Self	8	
15	384593	(000000–	) Screw, M8 X 20mm	3	
16	384577	(000000–	) Washer, Flat, M8.4	4	
17	384739	(000000–	) Support, Battery	3	
18	384591	(000000–	) Nut, M8	3	
19	384823	(000000–	) Screw	1	
20	384500	(000000–	) Horn	1	
21	1011735	(000000–001617	) Switch, Safety, Shutoff	1	
21	1051964	(001618–	) Switch, Safety, Shutoff, [S–Drive, S12]	1	
22	384701	(000000–	) Switch	1	
23	384621	(000000–	) Screw, M4 X 20mm	2	
24	384742	(000000–	) Key	1	
25	384588	(000000–	) Nut, M4	4	
26	384598	(000000–	) Screw, M6 X 16mm	1	
27	384645	(000000–	) Washer, Flat, M6.4	2	
28	384629	(000000–	) Nut, M6	1	
29	384825	(000000–	) Screw	2	
30	384737	(000000–001617	) Circuitboard	1	
30	1051961	(001618–	) Controller, [S–Drive, S12]	1	
31	384811	(000000–	) Washer	2	
32	384831	(000000–	) Nut	2	
33	384806	(000000–	) Buzzer, Backup	1	
34	384826	(000000–	) Screw	2	
35	384633	(000000–	) Nut, M4	2	
36	384644	(000000–	) Washer, Flat, M4.3	2	
37	384743	(000000–	) Switch, Key	1	
38	384851	(000000–	) Cover, Pot	1	
39	1014832	(000000–	) Switch, Horn	1	
40	384748	(000000–	) Sprocket	1	
41	384596	(000000–	) Sleeve, Adj	1	
42	384749	(000000–	) Potentiometer	1	
43	384750	(000000–	) Plug	1	
44	384848	(000000–	) Support, Relay	1	
45	384849	(000000–	) Adapter, Relay	2	
46	384745	(000000–	) Support, Relay	3	
47	384746	(000000–	) Relay, Main, 24vdc 50a	3	
48	384850	(000000–	) Adapter, Fuse	1	
49	384747	(000000–	) Fuse, 01a	1	
▽	50	384505	(000000–	) Plate, Panl, Instmt	1
▲		384506	(000000–	) Label, Panl, Instmt	1
	51	9006259	(001618–	) Sleeve, Sprocket, Drive [S12]	1

Fig. 12 – Battery and Charger Group

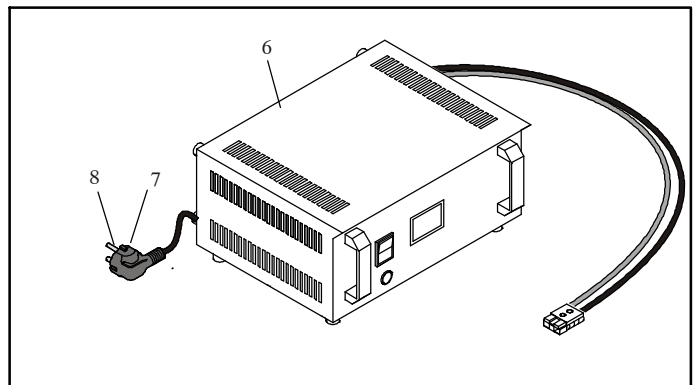
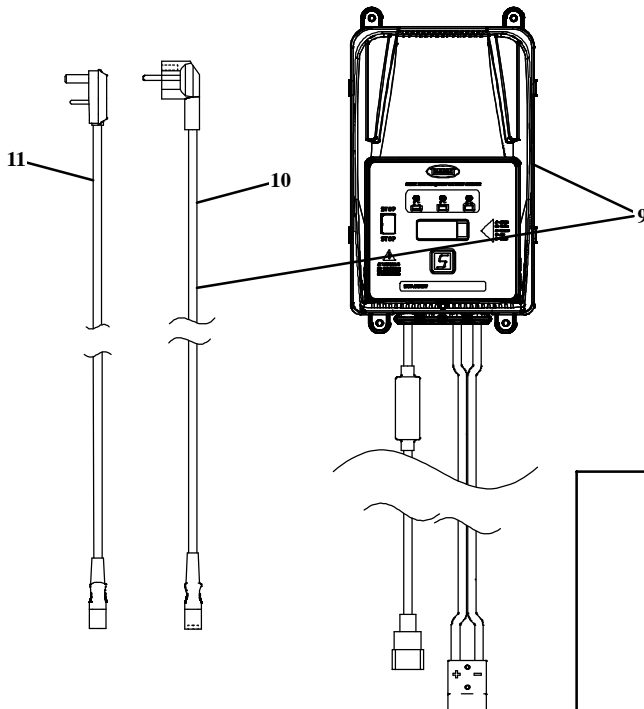
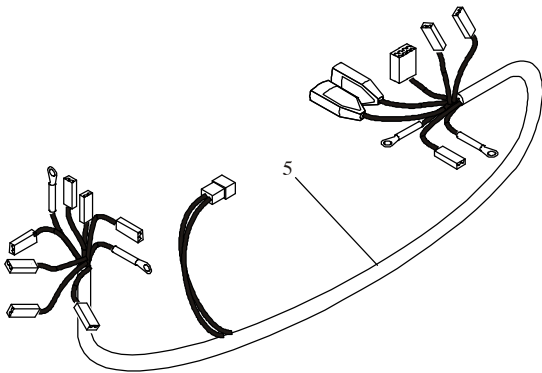
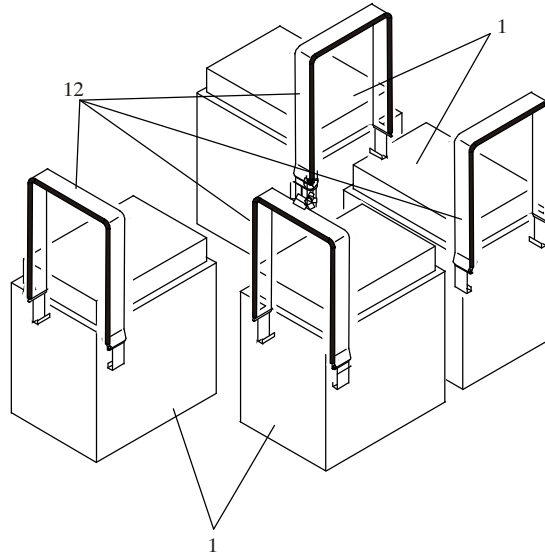
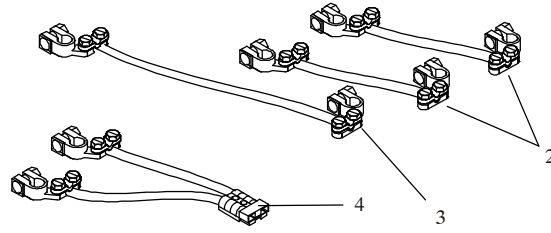
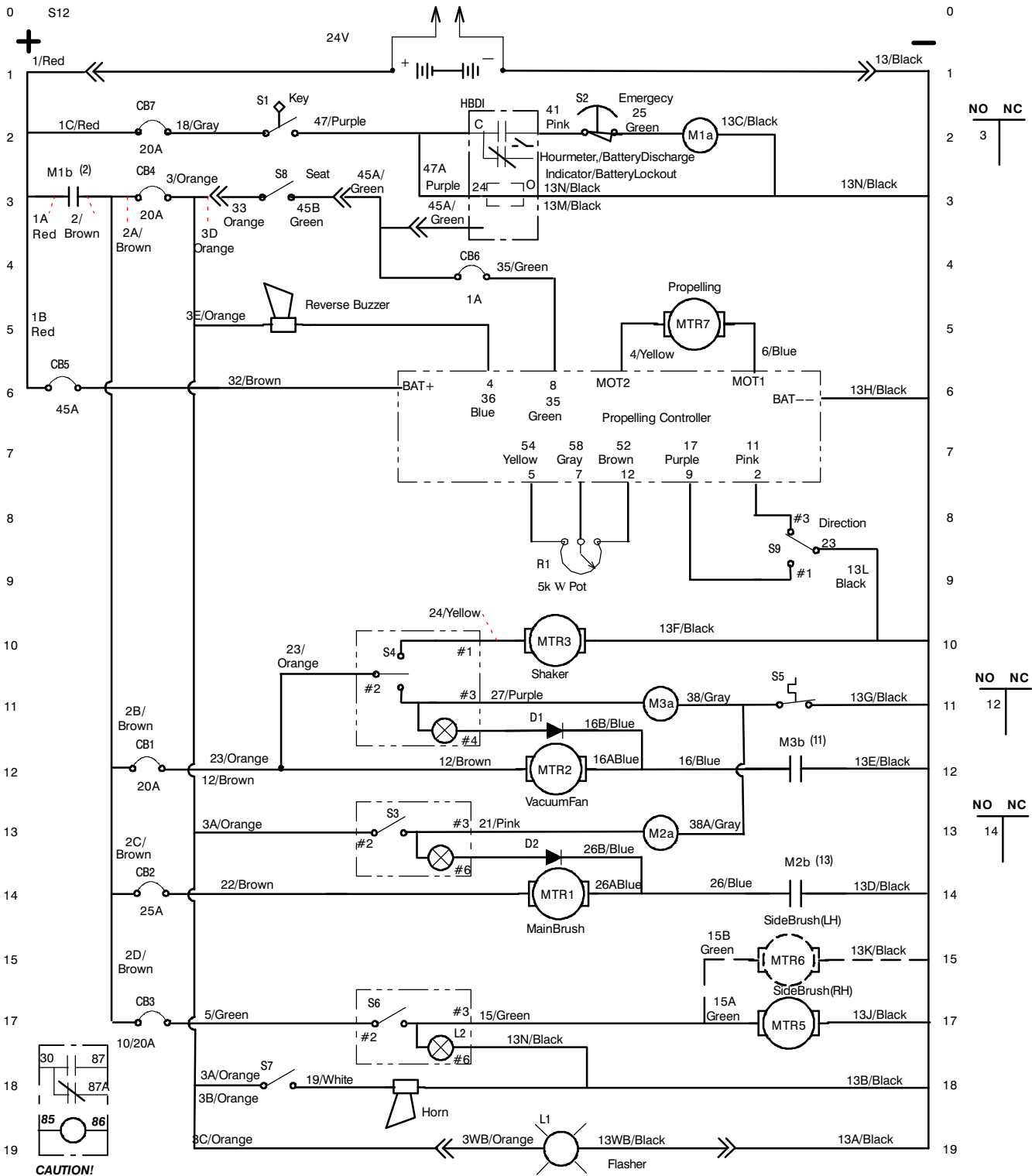



**Fig. 12 – Battery and Charger Group**

	<b>Ref.</b>	<b>Part No.</b>	<b>Serial Number</b>	<b>Description</b>	<b>Qty.</b>
▽		995450	(000000–	) Battery Kit Semi Traction, 4x6V/185Ah/5H	1
▲	1	1041456	(000000–	) Battery, 06Vdc 185Ah [5H, T105Ap]	4
▲	2	99343	(000000–	) Cable, Battery, 16Mm2 290L Blk, 2 Clamp	2
▲	3	99453	(000000–	) Cable, Battery, 16Mms 460L Blk, 2 Clamp	1
▲	4	991273	(000000–	) Cable Assy, Battery, 2 Clamp To Anderson	1
▽		995451	(000000–	) Battery kit [Mf monoblocs 4x6V/180Ah/5H	1
▲	1	994203	(000000–	) Battery, 06Vdc 180Ah [5H, Gf06180]	4
▲	2	99343	(000000–	) Cable, Battery, 16Mm2 290L Blk, 2 Clamp	2
▲	3	99453	(000000–	) Cable, Battery, 16Mms 460L Blk, 2 Clamp	1
▲	4	991273	(000000–	) Cable Assy, Battery, 2 Clamp To Anderson	1
▽		995452	(000000–	) Battery Kit Tract. Monoblocs 4x6V/175Ah	1
▲	1	1214518	(000000–	) Battery, Wet, 6Vdc, 180Ah	4
▲	2	99343	(000000–	) Cable, Battery, 16Mm2 290L Blk, 2 Clamp	2
▲	3	99453	(000000–	) Cable, Battery, 16Mms 460L Blk, 2 Clamp	1
▲	4	991273	(000000–	) Cable Assy, Battery, 2 Clamp To Anderson	1
	5	384529	(000000–001617	) Harness	1
	5	1051962	(001618–	) Harness, Main, [S–Drive, S12]	1
▽	6	1041701	(000000–Sept2012	) Charger, 24Vdc 025A Wet Sb050r 230Vac (Replaced by 107178)	1
▲	7	1043746	(000000–Sept2012	) Cable, Charger Eu	1
▽	6	1041691	(000000–Sept2012	) Charger, 24Vdc 025A Gel Sb050r 230Vac (Replaced by 1071786)	1
▲	7	1043746	(000000–Sept2012	) Cable, Charger Eu	1
	8	1041716	(000000–Sept2012	) Cable, Charger Uk, Bc5 Bc7	1
▽	9	1071787	(Sept2012–	) Charger, 24Vdc 025A Wet Sb050r 230Vac	1
▲	10	1043746	(Sept2012–	) Cable, Charger Eu	1
▽	9	1071786	(Sept2012–	) Charger, 24Vdc 025A Gel Sb050r 230Vac	1
▲	10	1043746	(Sept2012–	) Cable, Charger Eu	1
	11	1041716	(Sept2012–	) Cable, Charger Uk, Bc5 Bc7	1
	12	384502	(000000–	) Strap, Battery	3

**Fig. 13 – Electrical Schematic**



**CAUTION!**

**LEGEND**

#	Description	Line	#	Description	Line	Conectornumbering
CB1	CircuitBreaker,FanMotor20A	12	S1	Switch_Key/Start	2	
CB2	CircuitBreaker,MainBrush20A	14	S2	Switch_Emergency	2	
CB3	CircuitBreaker,SideBrush10A(20A)	17	S3	Switch_MainBrush/Shaker	13	
CB4	CircuitBreaker,20AFlashlight,Horn	3	S4	Switch_VacuumFan/Shaker	11	
CB5	CircuitBreaker,45APropelling	6	S5	Switch_ThermoSentry	11	
CB6	CircuitBreaker,1ABoardActivating	4	S6	Switch_SideBrush	17	
CB7	CircuitBreaker,20AKeySwitch	2	S7	Switch_Horn	18	
D1	Diode,BlushingMainBrushrelaycoil	13	S8	Switch_Seat	3	
D2	Diode,BlushingVacuumfanrelaycoil	11	S9	Switch_TravelDirection	8	
HBDI	HourmeterBatteryDischargeindicator	2	M1	Relay_Main	3(2)	
L1	Light,Flasher	19	M2	Relay_MainBrush	12(11)	
L2	Light_Control,SideBrushswitch	17	M3	Relay_VacuumFan	14(13)	
R1	Potentiometer5k	9				

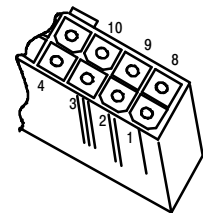

**Fig. 14 – Documentation Group**

<b>Ref.</b>	<b>Part No.</b>	<b>Serial Number</b>	<b>Description</b>	<b>Qty.</b>
	331356	(000000–	) Manual, Parts [S12, Ce]	1
	331358	(000000–	) Manual, Oprtr [S12, Cz, Ce]	1
	331359	(000000–	) Manual, Oprtr [S12, De, Ce]	1
	331360	(000000–	) Manual, Oprtr [S12, Dk, Ce]	1
	331361	(000000–	) Manual, Oprtr [S12, En, Ce]	1
	331362	(000000–	) Manual, Oprtr [S12, Es, Ce]	1
	331363	(000000–	) Manual, Oprtr [S12, Fi, Ce]	1
	331364	(000000–	) Manual, Oprtr [S12, Fr, Ce]	1
	331365	(000000–	) Manual, Oprtr [S12, Gr, Ce]	1
	331366	(000000–	) Manual, Oprtr [S12, Hu, Ce]	1
	331367	(000000–	) Manual, Oprtr [S12, It, Ce]	1
	331368	(000000–	) Manual, Oprtr [S12, NI, Ce]	1
	331369	(000000–	) Manual, Oprtr [S12, No, Ce]	1
	331370	(000000–	) Manual, Oprtr [S12, Pl, Ce]	1
	331371	(000000–	) Manual, Oprtr [S12, Pt, Ce]	1
	331372	(000000–	) Manual, Oprtr [S12, Ru, Ce]	1
	331373	(000000–	) Manual, Oprtr [S12, Se, Ce]	1
	331374	(000000–	) Manual, Oprtr [S12, Tr, Ce]	1
	331375	(000000–	) Manual, Oprtr [S12, Ee]	1
	331376	(000000–	) Manual, Oprtr [S12, Lv]	1
	331377	(000000–	) Manual, Oprtr [S12, Lt]	1
	331378	(000000–	) Manual, Oprtr [S12, Sk]	1
	331379	(000000–	) Manual, Oprtr [S12, Si]	1
	9005478	(000000–	) Manual, Oprtr [S12, Bg, Ce]	1
	9005479	(000000–	) Manual, Oprtr [S12, Ro, Ce]	1
	9011431	(000000–	) Manual, Oprtr [S12, Hr]	1
	9003459	(000000–	) Manual, Oprtr, [S12, Jp]	1

