



---

T560 **Small Ride-on Scrubber**

---

# LIST OF CONTENTS

<b>Precautions</b> .....	3	Overload reset switch .....	12
<b>Operation</b> .....	6	Reverse indicator light .....	12
Machine Components .....	6	Drain and clean the recovery tank	12
Control box instrument .....	7	Machine Troubleshooting .....	15
Working principle of the machine ·	7	<b>Maintenance</b> .....	16
Scrubbing method .....	8	Maintenance Table .....	17
Brush Information .....	8	Battery Charging .....	18
Machine Settings .....	8	Replace the brush plate, needle holder and cleaning pad.....	18
Installing the squeegee assembly ·	8	Brush plate and cleaning pad ...	18
Install brush plate/needle holder/ cleaning pad .....	8	Squeegee rubber strip .....	19
Inject clean water into the solution tank .....	9	Replacing squeegee rubber .....	19
Machine operation .....	9	Adjusting the squeegee rubber strip .....	20
Pre operation inspection .....	9	Pushing, dragging, and transporting machines .....	21
Before operation .....	9	Storing Machines .....	22
Scrubbing the floor .....	10	Freeze Protection .....	22
During machine operation.....	11	<b>Specifications</b> .....	23
Floor scrubbing method .....	11	General Machine Size/Capacity ·	23
Solution tank water level transparent tube .....	11	Type .....	23
Recovery tank sewage sensor ...	11	Tires .....	23
Battery consumption indicator light	12	Machine Dimensions .....	24

## Introduction

This manual is provided with various new models.

It includes necessary operation and maintenance instructions.



**Please read this manual thoroughly and understand the machine before operating or repairing it**

This machine has excellent performance. But only in the following cases can we get the best results at the lowest cost.

Be cautious when operating the machine.

- Maintain the machine regularly according to the maintenance instructions provided.
- Maintain the machine using components provided by the manufacturer or equivalent components.
- To view, print or download manuals, please visit online.

[www.tennantco.com/manuals](http://www.tennantco.com/manuals)



### Protect the environment

Please dispose of packaging materials and used machine components, such as batteries, in an environmentally friendly manner in accordance with local waste disposal regulations.



Always remember to recycle the items.

## Purpose

Automatic scrubbers are used for commercial purposes, such as hotels, schools, hospitals, factories, shops, offices, and rental services. They can scrub hard surfaces of indoor environments, such as concrete, stones, and synthetic materials. Please use the recommended floor cleaning agent. Do not use this machine on carpet surfaces. Use only recommended pads/brushes and floor cleaning agents available in the market. Do not perform anything other than those described in this operator's manual.

## Unpacking the machine

Carefully inspect the machine for signs of damage and immediately report the damage to the operator. If any items are missing, contact the dealer or Tennant.

To open the machine packaging, remove the tie straps, wheel stops, and transportation brackets. Carefully place the machine onto the lower pallet using the provided slope, ensuring that the brush head is in the raised position.

**Attention: The machine must be removed from the pallet using an inclined plane, otherwise it may cause damage to the machine.**

**Tennant Company**  
PO Box 1452  
Minneapolis, MN 55440  
Phone: (800)553-8033  
[www.tennantco.com](http://www.tennantco.com)

Tennant Cleaning System Equipment (Shanghai) Co., Ltd  
Address: Lane 928, Shenhong Road, Minhang District,  
Shanghai Room 608, Building 5, Jiahui, Hongqiao  
Tel: (8621) 6700 8000  
Fax: (8621) 6700 8006

Specifications and components are subject to change without prior notice.

Description of the original manuscript Copyright E2019-2017  
Tennant company.

All rights reserved.

### Important safety instructions - keep these instructions properly.

The following types of warning and preventive measures have appeared multiple times throughout this manual, and the meanings of their descriptions are:

#### **Warning**

Warning of dangerous or unsafe practices that may cause serious personal injury or death.

For safety reasons: Identify the operations that must be followed for safe operation of the machine.

The following information signs may pose a danger to the operator. Understand when these situations may occur and identify all safety equipment on the machine. Immediately report machine damage or faulty operation.

#### **Warning**

To reduce the risk of fire, explosion, electric shock or injury:

- Read the manual before operating the machine.
- Do not use or pick up combustible materials.
- Do not use the machine near flammable liquids, vapors, or dust.

This machine is not equipped with an explosion-proof motor. The motor may generate sparks during startup and operation. If the machine is used in areas with combustible vapors/liquids or combustible dust, it may cause a flash fire or explosion.

- Batteries may emit hydrogen gas, which may cause explosions or fires. Keep away from sparks and open flames when charging.

- Disconnect the battery and charger cables before cleaning and maintaining the machine.

Do not charge the battery with damaged power cords. Do not modify the plug.

If the power cord is damaged or disconnected, it must be replaced by the manufacturer or maintenance personnel or similar qualified personnel to avoid danger.

- Do not use it outdoors. Store it indoors.
- Do not touch the pad/cleaning brush with your hands when rotating.

 **Warning! Magnetic field hazards. Magnetic needle holder/cleaning brush, which can affect the normal operation of pacemakers or other medical implants.**

#### **For safety reasons :**

1. Do not operate the machine under the following circumstances:

- Without training and authorization.
- Have not read and understand the operator manual.
- Failure to follow machine guidelines in both thought and action.
- After consuming alcohol or medication.
- When using mobile phones or other types of electronic devices.
- If the operating conditions are not suitable.
- Located in areas with combustible vapors/liquids or combustible dust.
- Use gaskets or accessories not provided or approved by Tennant. The use of other mats may affect safety.
- Outdoor area. This machine can only be used indoors.
- The area where objects may fall.
- The environment is too dark to safely see the area for controlling or operating the machine.

2. Before operating the machine:

- Check the machine for any liquid leaks.
- Ensure that all safety equipment is in place and working properly.

3 When operating the machine:

- Can only be used according to the instructions in this manual.
- Immediately report machine damage or faulty operation.
- Wear work shoes with toes close together and not slippery.
- Slow down when turning.
- Slow down on slopes and smooth surfaces.
- Do not scrub on slopes with a slope exceeding 9%, and do not transport on slopes with a slope exceeding 21%.
- Follow the on-site safety guidelines for wet floor.
- Follow the mixing, handling, and disposal instructions on the chemical container.
- Do not carry passengers on the machine.
- Be particularly careful when reversing the machine.
- Keep children and unauthorized personnel away from the machine.
- It is not allowed to play with machines as toys.

### 4. Before leaving or repairing the machine:

- Park on a horizontal surface.
- Set the parking brake (if equipped).
- Turn off the machine and remove the key.

### 5. When repairing the machine:

- Before operating the machine, disconnect the battery connector and charger cable.

- All work must be done in areas with good lighting and high visibility.

- All maintenance work must be carried out by trained personnel.

- Use replacement parts provided or approved by Tennant.

- Do not make any modifications to the machine that are different from the original design.

- Do not lift the machine,

- Avoid moving components. Do not wear loose clothing or accessories, tie up your long hair and tie it up properly.

- When the charger is running, do not unplug the DC power cord of the built-in charger from the socket of the machine, as this may cause arcing. If the charger must be disconnected during charging, first disconnect the AC power cord.

- Do not use incompatible battery chargers as it may cause battery damage and may lead to a fire.

- Check if the charger cable is damaged.

- Maintain sufficient ventilation in the work area.

- Avoid contact with battery acid.

- Keep metal objects away from the battery.

- Do not power on spray or flush the machine with water pipe.

- When lifting the battery, use a crane or suitable auxiliary equipment.

- The battery must be installed by trained personnel.

- Wear the personal protective equipment required and recommended in this manual.



For safety reasons: wear protective gloves.



For safety reasons: wear eye protection devices.

### 6. When loading the machine onto or unloading it from a truck or trailer:

- Empty the water tank before loading the machine.

- Using slopes, trucks, or trailers that can support the weight of the machine and operator.

- Do not operate the machine on slopes exceeding 21%.

- When the slope exceeds 21%, a winch must be used.

- Before turning off the machine, lower the floor scrubber head and squeegee.

- Turn off the machine and remove the key.

- Set the parking brake (if equipped)

- Stuck the wheel of the machine car.

- Secure the machine with straps.

### 7. When using an optional lithium battery:

- Before operating or using the machine/battery, please read and understand the operating manual.

- Only use the battery charger provided with the lithium battery.

- It is strictly prohibited to disassemble the battery. Tearing the battery warranty label will result in the warranty becoming invalid.

- Do not touch or short-circuit the positive and negative electrodes of the battery with metal objects, and do not connect the positive and negative electrodes in reverse.

- Do not squeeze or impact the battery, otherwise it may cause the battery to heat up or catch fire.

- It is strictly prohibited to place the battery in fire or water to avoid explosion.

- Do not install, use, or store batteries in hazardous environments (live, damp, overheated, supercooled, or highly magnetized).

- Do not touch the battery with wet hands to avoid electric shock.

- Do not use flammable and volatile solvents such as alcohol to clean batteries and terminals to avoid ignition. If cleaning is required, please use a dry cloth to wipe.

- Charge with a designated charger and continuously charge for no more than 24 hours. Remove the plug from the power supply when the charger is not in use.

- When the battery experiences noise, abnormal temperature, leakage, or other abnormal situations, please immediately stop charging or using it.

- Please dispose of discarded batteries in accordance with local regulations, fully discharge them before disposal, and wrap the electrodes with insulating paper to prevent fire and explosion.

- Contact Tennant's authorized local and regulatory lithium battery transportation and storage organization.

## Machine Components



1. Reverse indicator light
2. Steering wheel
3. Operation panel
4. Charging interface
5. Hand brake handle
6. Foot switch
7. Foot brake pedal
8. Drive wheel
9. Water valve handle
10. Waterproof rubber strip
11. Guiding wheel
12. Sewage pipe
13. Solution tank cover
14. Brush plate
15. Big casters
16. Squeegee guide wheel
17. Squeegee castor
18. Squeegee components
19. Action pipe
20. Hanger



## Control box instrument

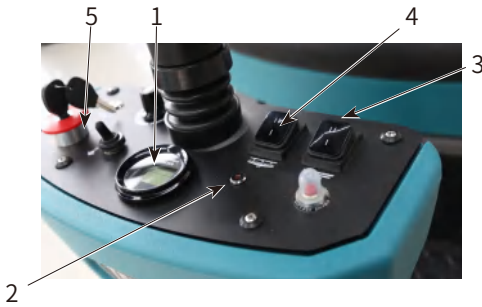

1. Battery power meter
2. Fault indicator light
3. Brush plate motor switch
4. Squeegee motor switch
5. Main power switch
6. Horn button
7. Forward and backward switch
8. Overload circuit breaker
9. Speed control switch

## Console symbols

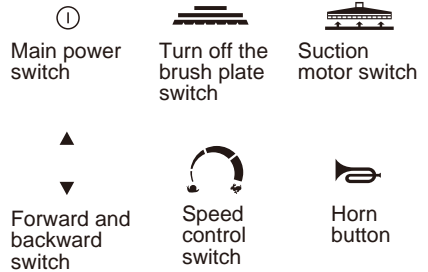

## Working principle of the machine



The cleaning components of the machine are: a solution tank, brush plate, needle holder or cleaning pad, a squeegee component, a vacuum motor, and a recovery tank.

The buttons on the control panel can control the sweeping function of the machine. Turn on the brush plate motor switch and the squeegee lifting switch, and lower the brush plate and squeegee. Place the forward and backward switches in the "forward" position, adjust the speed switch (according to different ground conditions, adjust to the appropriate speed), then release the manual brake, press the pedal, and start cleaning.

There are two available plate brushes with a brush head width of 350mm (13 inches).

Note: The number and type of dirt particles will

determine the type of brush head or scouring pad used. If you need special advice, please refer to this manual. It is in the (Brush Head Information) section or contact a sales representative.

### Scrubbing method

The water and cleaning agent in the solution tank flow to the brush plate and the floor through an electromagnetic valve. The solution mixed with cleaning agent and water is used to rotate the brush head to wash the floor. While the machine is moving forward, the suction pump sucks the sewage on the floor into the recovery tank through the vacuum motor.

### Brush information

PP brush - recommended for use on hard surfaces, clean without leaving scratches.

Needle holder and scouring pad are used for floors and painted floors to make their surfaces smooth and bright.

Attached:

Model of needle holder and scouring pad:  
350mm foam needle holder+NP-500 buckle  
FBP180002.

Brush plate model:

350mm scrubbing brush+NP-500 buckle  
FBP180002.

## Machine Settings

### Install the squeegee

1. Park the machine on a flat surface.
2. Please turn off the machine key switch.

For safety reasons: when leaving or repairing the machine, stop the machine on a level surface, turn off the machine and pull out the key.

3. Remove the squeegee from the squeegee bracket and tighten the two knobs.
4. Connect the suction pipe and the squeegee assembly as shown in the diagram.



The squeegee is preset at the factory. If you need to adjust the squeegee components, please refer to the section "Adjusting the squeegee" in this manual.

### Install brush plate/needle holder/scouring pad

If you want to install a brush plate or scouring pad, please refer to the section "Replacing the Brush plate, Needle holder, and Scouring pad" in this manual.



## Inject clean water into the solution tank

For safety reasons: when leaving or repairing the machine, stop the machine on a level surface, turn off the machine and pull out the key.

There is a hose injection hole at the rear of the machine.



**⚠ Warning:** Flammable substances may cause explosions or fires.

**Scrubbing method:** Open the injection hole of the solution tank and inject some water (please do not exceed 60 degrees Celsius). According to the mixing proportion instructions on the solution tank, pour the required cleaning agent into the solution tank, and then inject warm water into the solution tank. At the same time, add defoamer to the recovery tank (please refer to the instructions on the defoamer for the proportion).

For safety reasons: When using the machine, please follow the mixing ratio and handling instructions on the chemical container.

**Note:** If using a bucket to inject clean water into the solution tank, please ensure that the bucket is clean; Do not use the same bucket to inject clean water and discharge sewage.

**Attention:** If using traditional floor scrubbing methods, please always use the recommended cleaning agent. If the machine is damaged due to improper use of cleaning agents, the manufacturer shall not be liable for warranty.

## Machine operation

### Pre-operation inspection

- Check the machine for any liquid leaks.
- Check if the sealing ring of the solution tank cover is damaged or has foreign objects.
- Check if the filter screen of the vacuum motor is blocked.
- Check the condition of the brush. Remove the thread, bandage, wire, plastic packaging or other debris around the brush.
- Check if the solution tank is worn or dirty, or if the angle of the squeegee needs to be adjusted.
- Check if the suction pipes and suction ports of the squeegee are clogged with dirt or if the sewage pipes are broken.
- Drain and clean the recovery tank.
- Check if the brakes and steering wheel can operate normally.
- Check if the horn and reversing lights are functioning properly.
- Check the repair record to determine whether the machine maintenance is required.

### Before operation

Before scrubbing the floor, please take out the large debris, and take out the metal wire, thread ball, string, etc. that may be wrapped around the brush.

Please plan the scrubbing method in advance, and try to make long-term planning arrangements to minimize the number of downtime and startup. Please do not clean the entire floor or area at once.

Wipe it off beforehand to prevent spots from mottling.

## Inject clean water into the solution tank

### Scrubbing the floor

For safety reasons: Do not operate the machine until you have read and understood the operating manual.

1. Please turn on the switch key.
2. Turn on the lights (if equipped).
3. Please set the direction switch (forward or backward) according to the direction in which the machine needs to be moved.

Note 1: When the forward and backward switches of machine are set in the "forward" direction, it is normal to scrub the floor.

Note 2: When the forward and backward switches of the machine are set in the "backward" direction, the squeegee component will automatically lift, the vacuum motor will be turned off, and the backup light will light up to indicate a warning.

4. Press the push pedal to start scrubbing the floor.

**⚠ Warning: Flammable substances or active metals may cause explosions or fires, please do not pick them up.**

5. Release the foot switch, turn on the lifting motor switch of the squeegee, fold the squeegee, turn on the lifting switch of the brush plate motor, and fold the brush plate. Press the brake pedal, pull the manual brake handle to the left, turn off the power, and stop the machine.

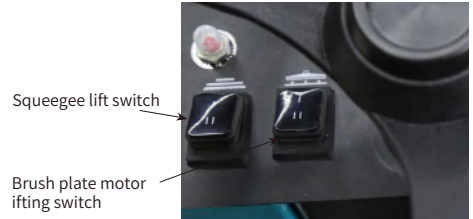
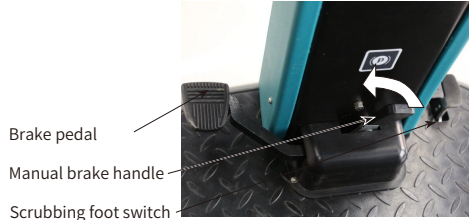

6. If it is necessary to stop quickly or operate on a sloping surface, the brake pedal can be used to control the machine. When scrubbing the floor, do not operate the machine on a slope with a gradient exceeding 7% (4 °).

For safety reasons: When using the machine, move slowly on slopes and smooth surfaces.

## During machine operation

Please try to go straight ahead to avoid hitting the column or scraping both sides of the machine. Overlap the cleaning route by a few centimeters (inches).

When the machine is moving, please avoid rotating the steering wheel greatly. The machine is very sensitive to the rotation of the steering wheel. Avoid sharp turns unless in an emergency.

When you reach the bottom of the walkway, clean it from the bottom to the opening of the walkway.

When cleaning, adjust the machine speed and water flow rate as needed, and try to use a medium speed and minimum water flow rate as much as possible.

Keep the machine moving to avoid damaging the floor.

If the scrubbing effect is not good, stop scrubbing and refer to machine troubleshooting.

## Scrubbing method

If there is too much foam, it is recommended to use defoamer to inject into the recovery tank. Replace the needle holder or cleaning pad as needed to clean.

Please pay attention to the battery power indicator to ensure that there is enough power for machine operation.

Please pay attention to the transparent tube indicated by the solution tank to ensure that it is not empty. Before refilling the solution tank, please clean the solution tank first.

lease remove the key before leaving the machine.

After scrubbing the floor, carry out daily maintenance procedures (refer to Machine Maintenance)

Driving the machine slowly on a slope: When going downhill, use the brake pedal to control the machine and the rotary speed control switch to slow down the machine speed. Wash the ground when the machine is going uphill instead of downhill.

For safety reasons: When using the machine, move slowly on slopes and smooth surfaces.

Do not operate the machine in areas with ambient temperatures exceeding 43 °C (110 °F)

Make a machine. Do not turn on the floor scrubbing function in areas with an ambient

temperature below 0 °C (32 °F).

The maximum rated slope of the machine during sweeping operation is 12%, and the maximum rated slope of the transport machine is 30%.

## Water level transparent pipe of the solution tank

The water level pipe of the solution tank can simply and clearly indicate the real-time water level, facilitating machine operation and ensuring normal use of the machine.



Water level transparent tube of the solution tank

## Recovery tank sewage sensor

When the recovery tank is full, the sewage sensor of the recovery tank will cut off the power supply of the vacuum motor, but it will not stop its function. Please timely discharge the sewage from the recovery tank in order to continue normal use.

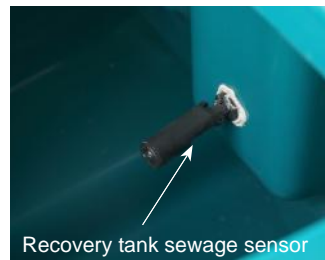

Recovery tank sewage sensor

The battery meter displays the battery level.

## Battery power meter

When the battery is fully charged, the screen display is 100%. As the electricity consumption decreases, the percentage decreases. When the percentage is below 5%, the brush plate stops working.

Note: To extend the lifespan of the battery, please make sure to charge the battery in a timely manner after the machine is used.



Battery level display

## Overload reset switch

The overload reset switch can provide emergency protection for the device and automatically cut off power when the circuit is overloaded.



## Reverse indicator light



## Drain and clean the recovery tank

After cleaning or when the sewage sensor of the recovery tank cuts off the power supply of the vacuum motor, please drain and clean the recovery tank. Then fill it up completely. The water tank can be cleaned.

1. Please immediately push the machine to the clean water discharge ditch.
2. Please turn off the machine key switch.

For safety reasons: when leaving or repairing the machine, stop the machine on a level surface, turn off the machine and pull out the key.

3. Remove the drain pipe from the recovery tank. When holding the drain pipe upwards, please open the upper cover and slowly place the drain pipe in the floor drain or sink.



4. The seat can be hung by tilting the operator seat forward and holding the seat spring lock.
5. Lift the cover of the recovery tank and rinse the inside of the recovery tank with clean water.



**Warning: Flammable substances may cause explosions or fires. Do not use flammable substances in the tank.**

Do not use steam to clean the water tank, as high heat can damage the water tank and components.

## Discharge solution tank

6. Rinse the float sensor inside the recovery tank with clean water.
7. After the recovery tank is drained, cover the drain pipe cover and replace the drain pipe in its original position.
8. Turn the sewage filter counterclockwise and if it becomes dirty, gently wash it with a damp cloth or brush. Please wait until the filter screen is dry before installing it back into the machine. Do not rinse the filter screen with a water gun.



9. Cover the recovery tank and ensure that there are no other foreign objects around it, as shown in the following figure.

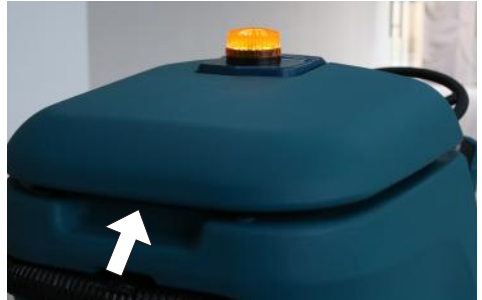

10. When removing the drain pipe and holding it upwards, please open the drain pipe cover and slowly place the drain pipe in the sewer or sink.





11. Rinse the solution tank with clean water, then rinse the float sensor on the back side of the tank, and rinse the filter screen at the bottom of the tank.

12. Open the solution tank cover from the back and inject clean water to clean the water tank. Wipe the bottom of the cover, first install the sealing ring of the solution tank, and then reinstall the cover.



13. Check if the clean water filter screen is clean. If there are any foreign objects, use a special wrench to unscrew the transparent cover counterclockwise, remove the filter screen, clean it thoroughly, and then install it.



14. After the solution tank is drained, install the upper cover of the clean water injection port and replace the sewage pipe in its original position.

## Machine troubleshooting

Problems	Reason	Solution
Insufficient suction	The vacuum motor has been turned off	Turn on the vacuum motor
	Wear of squeegee blade	Turn the direction or replace the squeegee blade
	Squeegee displacement	Adjusting the squeegee
	Sewage suction pipe is blocked	Clear blockage
	Sewage filter screen becomes dirty	Clean the filter
	There are debris on the squeegee	Remove garbage
	The suction pipe connected to the squeegee is not connected or damaged	Reconnect or replace the suction pipe
	The cover of the recovery tank or sewage pipe is not tightly covered	Check for any obstructions and cover properly
vacuum motor does not work	The vacuum motor switch has been turned off	Turn on the vacuum motor switch
	The recovery tank is full	Drain the recovery tank
	Foam filled the recovery tank	Empty the recovery tank Reduce the use of cleaning agents or add an appropriate amount of defoamer to the recovery tank
	Dirty recovery tank sensor Damaged or obstructed	Clean or replace the sensor
Low or no water output from the brush plate	The solution tank is empty	Fill up the solution tank
	Closed the water valve	Open the water valve
	Solenoid valve damaged	Solenoid Valve Replacement
	The filter screen of the solution tank is blocked	Drain the solution tank, take out the filter screen of the solution tank, clean it and put it back Loop.
Poor floor scrubbing effect	Using unsuitable cleaning agents or brushes	Contact Gaomei maintenance personnel
	The recovery tank is full	Empty the recovery tank
	Clear the solution tank empty	Adding water to the solution tank
	Debris on the needle holder or cleaning pad	Remove garbage
	Worn washing brush	Replacing the brush
	Low battery power	Charge the battery until the charger is turned off



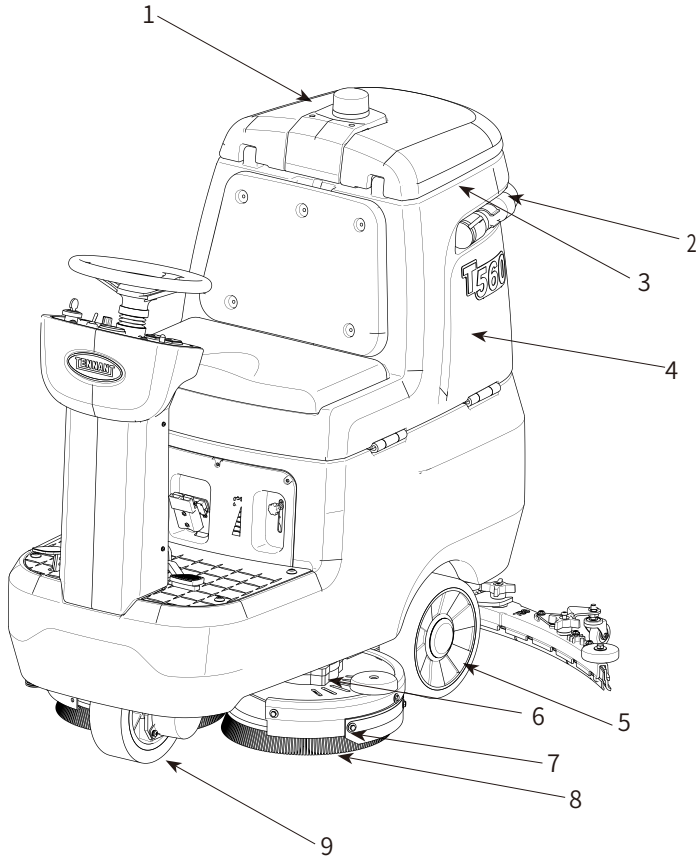



## Maintenance table

The following table identifies the responsible persons for each program

O=Operator

T=specially trained personnel

Interval period	Responsible person	Inspection and maintenance points	Description	Procedures
daily	O	8	Brush plate/needle holder Cleaning pad	Check the height of the brush plate/needle holder
	O	2	recovery tank	Check for damage and wear or debris
	O	1	Sewage guide cover	Cleaning
50 hours	O	7	Brush plate waterproof blade	Check for damage and wear
100 hours	T	3	Sealing ring of recovery tank	Check for damage and wear
200 hours	T	4	Maintenance-free battery electrodes and wiring	Check and clean
500 hours	T	1	Vacuum motor	Check the motor brush (check every 100 hours after the first 500 hours of operation)
	T	6	Brush plate motor	Check the motor brush (check every 100 hours after the first 500 hours of operation)
	T	9	DRIVE-MOTOR	Check the motor brush (check every 100 hours after the first 500 hours of operation)
	T	5	Big casters	Check for damage and wear

Note: more frequent maintenance may be required under extreme dusty conditions.

## Battery charging

Important: When charging, make sure that the charger has been properly set according to the type of battery.



1. Push the machine onto the flat and dry floor.

Note: Please make sure that the area is well ventilated.

2. Please turn off the machine key switch.

For safety reasons: when leaving or repairing the machine, stop the machine on a level surface, turn off the machine and pull out the key.

4. Plug the charger connector into the battery charging connector.

5. Add a microswitch at the charging interface, which will trigger when inserted into the battery. The entire machine is in a charging state and cannot work in this state, which improves safety during charging.

## Replace the brush plate, needle holder, and cleaning pad

1. Park the machine on a flat surface and determine the raised position of the brush plate motor.

2. Please turn off the machine key switch.

For safety reasons: when leaving or repairing the machine, stop the machine on a level surface, turn off the machine and pull out the key.



## Brush plate and cleaning pad

The machine is equipped with a brush plate and a cleaning pad, and daily checks are made to ensure that there are no wire tangles on the brush plate and driving hub. In addition, the brush plate should also be checked for damage and wear.

For safety reasons: when leaving or repairing the machine, stop the machine on a level surface, turn off the machine and pull out the key.

If many bristles on the brush plate are missing or the length is less than 10mm (0.38 inches), please replace the brush.

Before use, please install the cleaning pad on the cleaning pad drive plate, and the needle seat is used to fix the cleaning pad.

After use, it is necessary to immediately clean the cleaning pad with soap and water. Do not use high-pressure water to clean the cleaning pad. Hang or lay the cleaning pad flat to dry.

Note: Please replace the entire set of brush plates and cleaning pads, otherwise the application of force on the brush plates or cleaning pads may vary.

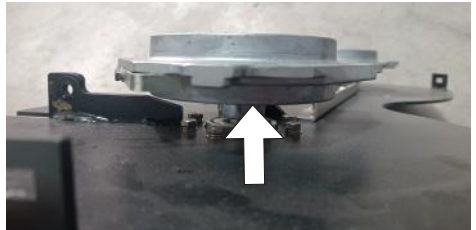
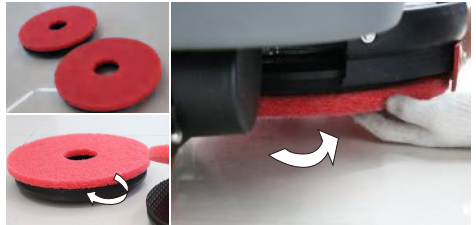

## Squeegee Blade

The squeegee blade is used to introduce wastewater and allow the suction motor to suck it into the recovery tank through the suction pipe.

Check the wear of the squeegee blade daily. If the squeegee blade is half worn, turn the direction or replace the blade.

The squeegee component can be removed from the squeegee bracket during transportation of the machine, and the fixing nut of the squeegee component can be unscrewed counterclockwise to prevent damage.



Unplug the suction pipe



Unscrew the fixing nut counterclockwise

## Replace (turn direction) the squeegee blade

1. Park the machine on a level ground and ensure that the brush motor and squeegee are in the raised position.

2. Please turn off the machine key switch.

For safety reasons: when leaving or repairing the machine, stop the machine on a level surface, turn off the machine and pull out the key.

3. Remove the squeegee component from the machine, loosen the four yellow hand-screwed nuts on the squeegee, and remove the blade after the main body of the squeegee is loose.



4. When installing the squeegee, check if the squeegee blade is worn. If one side is worn, replace it with the other side for installation. If both sides are worn, replace it with a new squeegee blade.

When replacing a new blade, place the ones with notches on the edge of the blade in front of the squeegee component, and place the ones without notches behind the squeegee component. After pressing the front and rear blade into the corresponding clamping holes, tighten the yellow

hand tightened nuts at both ends. As shown in Figure below.



7. Install the squeegee back onto the squeegee bracket, and install the suction pipe. Pay attention to the direction of the suction pipe opening, as shown in the figure:



### Adjusting the squeegee

Adjust the squeegee to ensure that the edge of the squeegee can fully contact the floor. Please make this adjustment on a flat surface. For safety reasons: when leaving or repairing the machine, stop the machine on a level surface, turn off the machine and pull out the key.

1. Firstly, place the machine on a stable floor, remove the squeegee component, turn on the squeegee switch button, and lower the squeegee bracket;

3. Press the squeegee switch button first, lift the squeegee bracket, install and tighten the squeegee component, and complete the debugging;



4. After proper adjustment of the squeegee, the squeegee blade should be able to bend as shown in the figure during machine operation.



2. The machine cleans different floors, and the contact height between the squeegee and the floor is also different, such as floor tiles, paints and stone floors:

13MM (6 threads are exposed by visual inspection of the nut); The cement floor is: 12MM (with 5 threads exposed by visual inspection of the nut),

## Pushing, dragging and transporting machine

Push or drag the machine

If the machine is turned off, you can push it forward or backward, but you cannot drag it from the front.

For safety reasons: do not operate the machine when the electromagnetic brake is released. Before attempting to push or drag the machine, please interrupt the push motor wiring harness and release the brake.

Only push or drag the machine on a flat surface. Do not exceed 3.2k p/h (2mph), and do not try to push or drag the machine at high speed.

Immediately push or tow the machine, please lower the manual brake handle.

## Transporting the machine

When handling the machine with a truck or trailer, be sure to follow the following procedures:

1. Raise the squeegee component and brush plate motor.

For safety reasons: When loading or unloading the machine onto or from a truck or trailer, the trash can must be emptied before loading the machine.

2. Use the recommended device to load and unload the machine.

For safety reasons: When transporting the machine, use the recommended handling device to load and unload the machine from the truck or trolley. 3. Place the front of the machine against the front of the truck or trailer.

Place obstacles behind each drive wheel to prevent the machine from sliding.

5. Bind the rack of the machine with ropes and then tie it to the trailer or truck to prevent the machine from tilting.

For safety reasons: when transporting the machine, use ropes to fix the machine on the vehicle plate.

## Storing the machine

When storing the machine for a long time, please take the following steps.

1. Drain and clean the solution tank and recovery tank, open the recovery tank for ventilation.
2. Park the machine in a cool and dry area. Do not expose the machine to rain and please store it indoors.
3. Take out the battery, or charge the battery every 3 months (be sure to fully charge it).

## Antifreeze protection

For safety reasons: when leaving or repairing the machine, stop the machine on a level surface, turn off the machine and pull out the key.

1. Empty the water from the solution tank and recovery tank.
2. Pour 2 gallons (8 liters) of propylene glycol based/RV antifreeze into the solution tank without diluting.
3. Turn on the machine and operate the solution flow system. Turn off the machine when the antifreeze appears in the scrubbing head.

## The Led light of the smart charger indicates the working status

Led light	Indicates status	Working state
LED1、LED2	Flashing, fan not running	Pre charging state [Charging time: 3 hours]
LED1、LED2	Red light on, fan running	Constant current state [Charging time: 7-8 hours]
LED1、LED2	Red light on, fan running	Constant voltage state [Charging time: 4.5 hours]
LED1、LED2	LED1 lights up in red, LED2 lights up in green Lights and fan not running	Low constant current state [charging time 4.5 hours]
LED1、LED2	LED1 light off, LED2 green light on, fan not running	Charge Complete
Remarks		
Several situations when LED2 lights up with a red light	1. Load short circuit	
	2. Wire connection reversed	
	3. Short circuit in battery line	
	4. Over temperature - LED2 lights up with an orange light	

## General machine size/capacity

Project	Size/Capacity
Length	1310mm
Height	1200mm
Width	800mm
Squeegee Width	1049mm/973mm
Brush Diameter	13"x2
Cleaning width	700mm
Solution Tank Capacity	70L
Recovery tank capacity	75L
Weight/without standard battery components	164Kg

Sound pressure level LPA	72dB
--------------------------	------

## Type

Type	Quantity	Voltage	Battery capacity	Weight
Battery (standard)	2	24V	176Ah 10hr	46Kg x 2

Type	Use	VDC	KW
Electric motor	Brush Plate Motor	24	0.4x2
	Vacuum motor	24	0.55
	Driving motor	24	0.4

Type	VDC	Ampere	Hz	VAC
Charger (intelligent)	24	25	50	220

## Tires

Position	Type	Size
Front wheel (1)	Solid	250mm(OD) x80mm wide
Rear-wheel	Solid	270mm(OD) x80mm wide

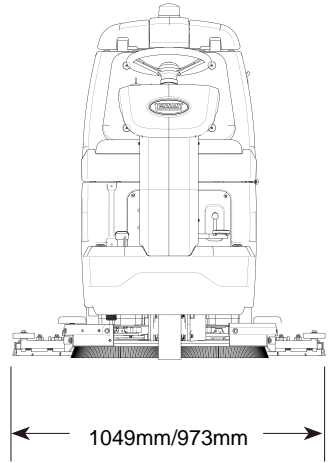
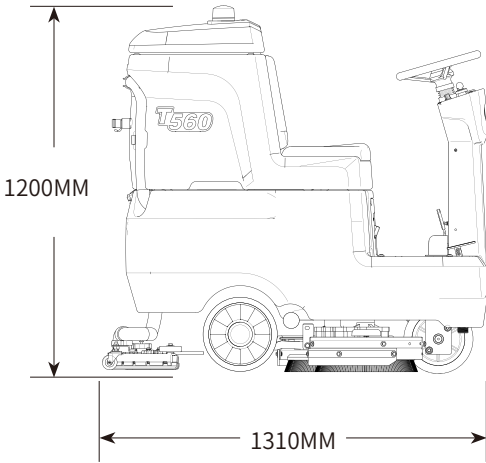
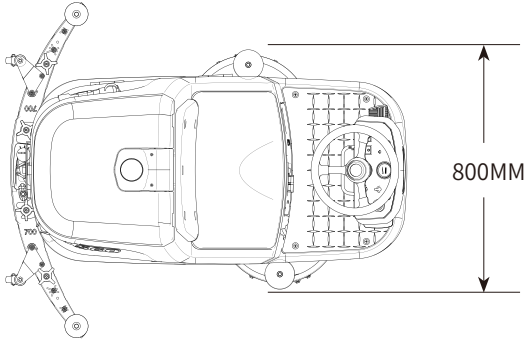



## Product Warranty Card(Main Card)

(The product warranty card is the main evidence for warranty service, Keep Properly

### **Warranty:**

Within the warranty period, if any fault condition happens by normal use under the instruction of operation manual, it will be repaired for free. Please take the warranty card and purchasing invoice for free repair.

During the warranty period, if have any of below situation, it must charge for the repair:

1. Do not provide the original warranty card and purchasing invoice accordingly.
2. Any malfunction or damage caused by improper use, improper self repair or renovation on machine.
3. Any damage or broken caused during transportation, delivery or fallen down after buying.
4. Any malfunction or damage caused by use other undesignated power(voltage, hertz, etc) or unusual voltage.
5. Accessories like machine appearance, dust separator, filter, electric wire, soft hose and metal pipes etc.

Within the warranty period, machine will be repaired for free based on above agreed terms. Any losses due to the malfunction will avoid the responsibility of manufacturer.

**User name:** \_\_\_\_\_

**Address:** \_\_\_\_\_

**Invoice number:** \_\_\_\_\_

**Date of purchase:** \_\_\_\_\_

**Machine sales unit:** \_\_\_\_\_

**Address:** \_\_\_\_\_

Product Warranty Card(Vice Card)

1.Product information:

Product Model and Name: \_\_\_\_\_

Serial No: \_\_\_\_\_

2. User Information: \_\_\_\_\_

Final User Company: \_\_\_\_\_ Tel: \_\_\_\_\_

Address: \_\_\_\_\_ Fax: \_\_\_\_\_

E-mail: \_\_\_\_\_ Post Code: \_\_\_\_\_

3. Sales Company Information: \_\_\_\_\_

Sales Company Name: (Effective seal) \_\_\_\_\_

Address: \_\_\_\_\_

Contact: \_\_\_\_\_ Tel: \_\_\_\_\_

Post Code: \_\_\_\_\_ Sales Date: \_\_\_\_\_

In order to achieve the company's service commitment and improve customer services, the company will establish a customer information file in the computer system.

1. Fill the main and vice card of Product Warranty Card and send them back to the company customer service for file with in 1 month after buy.

The mail address is:

**Hefei Gaomei Cleaning Equipment Co., Ltd**

**Add: Building 1, No. 501, Xiangpu Road, High-tech Zone, Hefei, China.**

2. If the main card of Product Warranty Card or the purchasing invoice lost, still can inquire on the customer service file for legal rights.

Cut here